

## DC1010/DC1020/DC1030/DC1040

## DIGITAL CONTROLLERS

## Specification

### Overview

The DC1000 Series are microprocessor-based controllers designed with a high degree of functionality and reliability at a competitive price. The controllers are available in different formats: 48x48 (1/16 DIN), 48x96 (1/8 DIN), 72x72 (3/16 DIN), 96x96 (1/4 DIN). This controller series is ideal for the control of temperature, humidity, pressure, flow etc. in a variety of applications including:

- Plastic Processing
- Package Machinery
- Painting and coating
- Semiconductor packaging / Testing
- Dryers

### Features

#### • Easy to Configure

Different configuration levels provide easy access to parameters.

#### • Various Control Algorithm

Several different algorithms are available as follows:

- PID or ON/OFF Control
- Heat/Cool Control with 2 PID sets
- Motor Position Control  
(without slidewire feedback)

#### • Auto-Tuning Capability

Advanced auto-tuning function calculates the optimized PID values for your specific control system.



#### • Dual Display and Bar graph

Two large 4 digits display PV, SP and configuration parameters. One 10 LED bar-graph displays the control output (MV), and up to 8 LEDs display the status of the different outputs (Control, Alarm, ...) and also provide indication of the Auto/Manual and programmer states.

#### • Setpoint Programming

Two programs are available with a maximum of 8 segments. The 2 programs can be linked together and perform as a single 16 segment program.

#### • Extended Alarm Capability

Up to three different alarm outputs are available per instrument and 17 kinds of event modes can be assigned to each of alarm output.

#### • Communications

RS232 or RS485 (with ASC II & Modbus RTU Protocol) is optionally available with a maximum communication speed of 38400 bps.

#### • IP65 Front Face Protection

IP65 rated front face permits use in applications where it may be subjected to moisture, dust conditions.

#### • Remote Setpoint Capability

The setpoint can be defined from a remote PLC or other controller.

#### • Manual & Automatic Modes

The control mode can be switched between Automatic and manual by clicking A/M key. (The A/M key is available with DC1020, DC1030 and DC1040)

#### • Global Approvals – CE & cUL

All models are CE certified as a standard, and UL approved version for all models are available optionally.

#### • Parameter Lock

A 4-digit security code prevents any unauthorized changes of parameters or configurations. Parameters can be hidden to user to prevent any mis-configuration of the unit.

Specifications					
<b>General</b>					
Rated power supply voltage		100 to 240V AC 50/60Hz, 8VA max. 15 to 50V DC, 10VA max.			
Insulation Resistance		Over 10M $\Omega$ under DC500V megger between input terminal and case(ground). Over 10M $\Omega$ under DC500V megger between output terminal and case(ground).			
Withstand voltage		1000V AC 50/60Hz for 1min across input terminal and case(ground) 1500V AC 50/60Hz for 1min across output terminal and case(ground)			
Operating Conditions	Ambient Temp.	0 to 50°C			
	Ambient Humi.	20 to 90%RH (non-condensing)			
	Rated Power Supply	100 to 240V AC 20 to 50V DC			
	Allowable Power Supply	85 to 264V AC 15 to 55VDC			
	Power Frequency	50 $\pm$ 2Hz or 60 $\pm$ 2Hz			
	Vibration Resistance	10m/s <sup>2</sup> (approx. 1G), 10 to 55Hz for 10min each X, Y, Z directions			
Transportation and storage conditions	Ambient Temp.	-25 to +65 °C			
	Ambient Humi.	10 to +95% RH (non-condensing)			
	Vibration Resistance	20m/s <sup>2</sup> (Approx. 2G), 10 to 55Hz for 2 hours each in X, Y, Z directions			
Exterior		Double insulation, Case and front panel : plastic			
Indication	PV/SP indication	4-digit, 7-segment display			
	Const value storage	Non-volatile memory(EEPROM)			
Mounting		Panel-mount			
Model		DC1010	DC1020	DC1030	DC1040
Exterior Size (unit: $\frac{mm}{inch}$ ) : W X H X D		50 X 50 X 97 (1.97X1.97X 3.82)	50 X 96 X 97 (1.97X3.78X3.82)	74 X 74 X 97 (2.91X2.91X3.82)	96 X 96 X 97 (3.78X3.78X3.82)
Panel Cutout (unit: $\frac{mm}{inch}$ ) : W X H		44.5 X 44.5 (1.75 X 1.75)	44.5 X 90.5 (1.75 X 3.56)	68.5 X 68.5 (2.97 X 2.97)	90.5 X 90.5 (3.56 X 3.56)
Global Approvals		CE, cUL			

Interval = 20.5mm (0.807 in)

Specifications		
Input/Output		
PV Input	Number of Point	1 point (TC, RTD or Linear)
	Type of input	TC: K, J, R, S, B, E, N, T, W, PLII, U, L RTD : Pt100, JPt100, JPt50 Linear : 4~20mA / 1~5V / 2~10V * Note 1 0~20mA / 0~5V / 0~10V * Note 1
	Range	Refer to Table 1-1. * Temperature unit : °C, °F (switchable)
	Sampling Time	250 ms
	Indication Accuracy	± 0.2% FS ± 1 digit (for details Table1-1)
	Cold junction accuracy	±1.0°C (under standard conditions)
	Input bias (offset)	LSPL ~ USPL
	Digital Filter	0 - 200 sec (0: filter off)
	Decimal Point	0000, 000.0, 00.00, 0.000
2 <sup>nd</sup> Input (RSP)	Type of input	0~20mA / 0~5V / 0~10V 4~20mA / 1~5V / 2~10V
	Sampling Time	250ms
CT Input	Type	Measure AC current of single phase SC-80T : 0.0~80.0A
	Sampling Time	500msec
	Indication Accuracy	1% FS
	Resolution	0.1A ac
	Weight	12g
	Dielectric strength	2500Vac, for 1 min between terminal and case

NOTE 1. When OUT1 is ON and CT input value is less than HBA set value for 5 seconds, AL1 is activated. Otherwise, AL1 is not activated.

Specification						
Model		DC1010	DC1020	DC1030	DC1040	
<b>Input/Output</b>						
Output 1	Relay output	SPST	SPDT	SPST	SPDT	
		3A, 220Vac, Resistive Load(100,000 time electrical life)				
	Voltage Pulse	PWM(SSR drive), ON: 20 Vdc, OFF: 0 V (max. load current 20mA) Open Time Terminal Voltage: 20 Vdc or less Time Proportional Cycle Time: 0-150 sec				
	Linear output	DC Current (mA) : 0~20mA, 4~20mA (load resistance 500Ω) DC Voltage (V) : 0~5V, 0~10V, 1~5V, 2~10V (max. load current 20mA) Accuracy ± 5% of Span Update Cycle 500m sec				
Output 2 (* Note 1)	Relay	SPST	SPST	SPST	SPST	
		3A, 220Vac, Resistive Load(100,000 time electrical life)				
	Voltage pulse	PWM(SSR drive), ON: 20 Vdc, OFF: 0 V (max. load current 20mA) Open Time Terminal Voltage: 20 Vdc or less Time Proportional Cycle Time: 0-150 sec				
	Linear	DC Current (mA) : 0~20mA, 4~20mA (load resistance 500Ω) DC Voltage (V) : 0~5V, 0~10V, 1~5V, 2~10V (max. load current 20mA) Accuracy ± 5% of Span Update Cycle 500m sec				
Output Direction (OUD)		HEAT(Direct)/COOL(Reverse) (Selectable)				
Control Mode		Auto/Manual operation is switchable.				
Aux. output	Output signal	SP, PV retransmission				
	No. of point	1 point				
	Type of output	4-20mA, 0~20mA, 0~5V, 0~10V, 1~5V, 2~10V				
	Accuracy	+/- 0.2% of span				
	Sampling time	500 ms				
Alarm output	Relay	AL1	SPST	SPDT	SPST	SPDT
		AL2	SPST	SPDT	SPST	SPDT
		AL3	-	SPST	SPST	SPST
		Rate	3A, 220Vac, Resistive Load(100,000 time electrical life)			

\* For Heat/Cool Control Output only.

Specification				
<b>PID Control &amp; Auto-Tuning</b>				
Proportional Band (P1,P2)		Proportional Band: 0.0 ~ 200.0%		
Integral time (I1, I2)		Integral time : 0 ~ 3600 sec		
Derivative time (D1, D2)		0 ~ 900 sec		
Auto-Tuning Value		0 ~ USPL		
HYS1, HYS2		0 ~ 1000 (for ON/OFF control)		
Dead Band (DB1)		Not defined.		
GAP1, GAP2		0 ~ 1000(for HEAT/COOL control)		
Cycle Time		0 ~ 150 sec		
<b>Communication</b>				
Speed		1200, 2400, 4800, 9600, 19200, 38400 bps		
Protocol		ModBus RTU, ModBus ASCII		
Parity check		Odd / Even		
Bit length		8		
Communication		RS232C, RS485		
<b>ALARMS(EVENTS)</b>				
Channel		Max. 3 channels(optional)with HBA		
Mode	Code	01 / 11	Deviation-High alarm (inhibit / no-inhibit)	
		02 / 12	Deviation-Low alarm (inhibit / no-inhibit)	
		03 / 13	Deviation High/Low Limit alarm (inhibit / no-inhibit)	
		04 / 14	Deviation High/Low Limit range alarm (inhibit / no-inhibit)	
		05 / 15	Absolute High alarm by PV (inhibit / no-inhibit)	
		06 / 16	Absolute Low alarm by PV (inhibit / no-inhibit)	
	SET VALUE		-1999~ USPL (Absolute value, Deviation value)	
	Activation Hysteresis		0 ~ 1000	
Timer		0 : Flicker 99M 59S : Continued alarm 00M 01S to 99M 58S : on delay Timer alarm		
Program	Code	07	Segment End alarm(in progress of program)	
		17	Program RUN	
System	Code	08	System Error ON	
		18	System Error OFF	
TIME	Code	19	Delaying timer (00Hours 00Min ~ 99Hour 59Min)	
HBA	Code	09	Heater Break Alarm for only AL1	

Specification		
Program (Optional)		
Program section	No. of patterns	2 (Program 1 & Program 2)
	No. of segments	8 segments/1 program
	Segment time	Segment time: Setting by set points(SP) and time (Max. 99hours 59minutes)
	Control output	0~100% When OUT=0%, Program End.
	WAIT function	Rear Wait Time may exceed set time of the particular segment. In this case, remaining time is set as 0 and pending; if the temperature that was measured does not reach target value $\pm$ WAIT set point. It proceeds to the next segment after it is confirmed that temperature reach the range of set point (target value $\pm$ WAIT)
		Setup range: $\pm 0 \sim 1000$ by decimal point.
	Repeat	Repeat(infinitely) / Non-repeat
	Program link	When Program number is 0, Link program 1 and 2.
	Program start	(1) Start from SP=0 (2) Start from PV
	Power Failure	Hot Start / Cold Start
TIME UNIT	Hour. Minute / Minute. Second	

Table 1-1

Analog Input Range (Thermocouple)						
Input Type	Code	Temperature Range		Indication Accuracy	Remarks	
		°C	°F			
TC (Note1)	K	K1	0.0~200.0	0.0~392.0	+/-0.2%FS	
		K2	0.0 ~ 400.0	0.0~752.0		
		K3	0 ~ 600	0~1112		
		K4	0 ~ 800	0~1472		
		K5	0 ~ 1000	0~1832		
		K6	0 ~ 1200	0 ~ 2192		
	J	J1	0.0~200.0	0.0~392.0	+/-0.2%FS	
		J2	0.0 ~ 400.0	0.0~752.0		
		J3	0 ~ 600	0~1112		
		J4	0 ~ 800	0~1472		
		J5	0 ~ 1000	0~1832		
		J6	0 ~ 1200	0 ~ 2192		
	R	R1	0~1600	0~2912	+/-0.2%FS	+/-2 °C under 100 °C +/-3.6 °F under 212 °F
		R2	0~1769	0~3216		
	S	S1	0~1600	0~2912	+/-0.2%FS	
		S2	0~1769	0~3216		
	B1		0~1820	0~3308	+/-0.2%FS	No guarantee at 0 ~ 400°C
	E	E1	0~800	0~1472	+/-0.2%FS	
		E2	0~900	0~1652		
	N	N1	0~1200	0~2192	+/-0.2%FS	
		N2	0~1300	0~2372		
	T	T1	-199.9~400.0	-199.9~752.0	+/-0.2%FS	+/-1 °C under -100 °C +/-1.8 °F under -148 °F
		T2	-199.9~200.0	-199.9~392.0		
		T3	0.0~350.0	0.0~662.0	+/-0.2%FS	
	W5Re/ W26Re		0~2300	0~3632	+/-0.2%FS	
			0~2320	0~4208		
	PLII	PL1	0~1300	0~2372	+/-0.2%FS	
		PL2	0~1390	0~2534		
	U	U1	-199.9~600.0	-199.9~999.9	+/-0.2%FS	+/-1 °C under -100 °C +/-1.8 °F under -148 °F
		U2	-199.9~200.0	-199.9~392.0		
U3		0.0~400.0	0.0~752.0	+/-0.2%FS		
L	L1	0~400	0~752	+/-0.2%FS		
	L2	0~800	0~1472			

Table 1-2

Analog Input Range (RTD)						
Input Type		Code	Input Type		Indication Accuracy	Remarks
			°C	°F		
RTD	JPt100	JP1	-199.9~600.0	-199.9~999.9	+/-0.2%FS	+/-0.5 °C under -100 °C +/-0.9 °F under -148 °F
		JP2	-199.9~400.0	-199.9~752.0		
		JP3	-199.9~200.0	-199.9~392.0		
		JP4	0~200	0~392		
		JP5	0~400	0~752		
		JP6	0~600	0~1112		
	DIN Pt100	DP1	-199.9~600.0	-199.9~999.9	+/-0.2%FS	+/-0.5 °C under -100 °C +/-0.9 °F under -148 °F
		DP2	-199.9~400.0	-199.9~752.0		
		DP3	-199.9~200.0	-199.9~392.0		
		DP4	0~200	0~392		
		DP5	0~400	0~752		
		DP6	0~600	0~1112		
	JPt50	JP.1	-199.9~600.0	-199.9~999.9	+/-0.2%FS	+/-0.5 °C under -100 °C +/-0.9 °F under -148 °F
		JP.2	-199.9~400.0	-199.9~752.0		
		JP.3	-199.9~200.0	-199.9~392.0		
		JP.4	0~200	0~392		
		JP.5	0~400	0~752		
		JP.6	0~600	0~1112		

Table 1-3

Analog Input Range (Linear)					
Input Type	Code	Source	Range	Indication Accuracy	Remarks
Linear	AN1	-10~10mV	-1999~9999	+/-0.1% of span	
	AN2	0~10mV			
	AN3	0~20mV			
	AN4	0~50mV			0-20mA, 0-1V, 0-5V, 0-10V
	AN5	10~50mV			4-20mA, 1-5V, 2-10V

Picture 1.1

## External Dimension

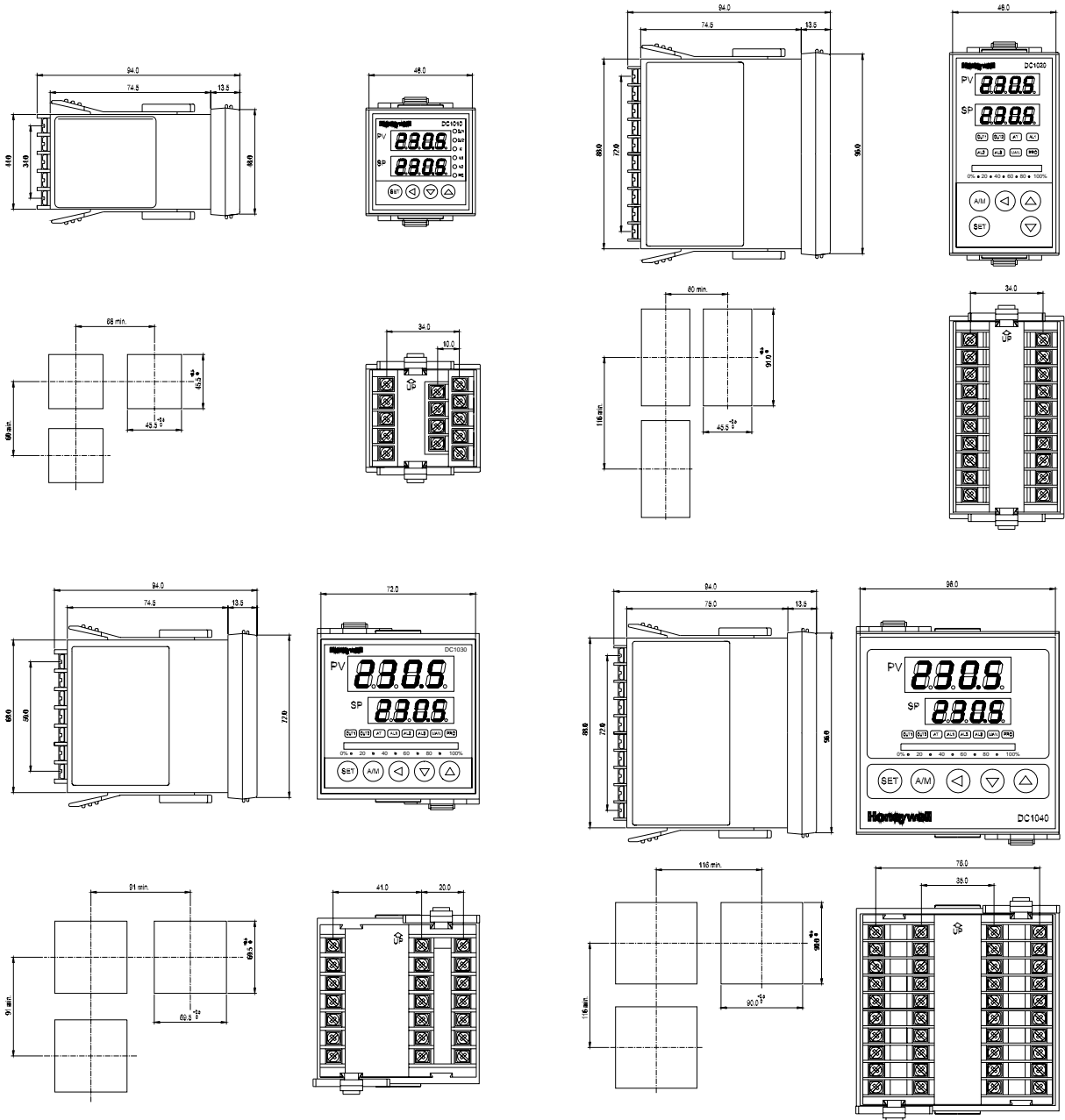

Picture 1-2

Wiring Diagram - DC1010

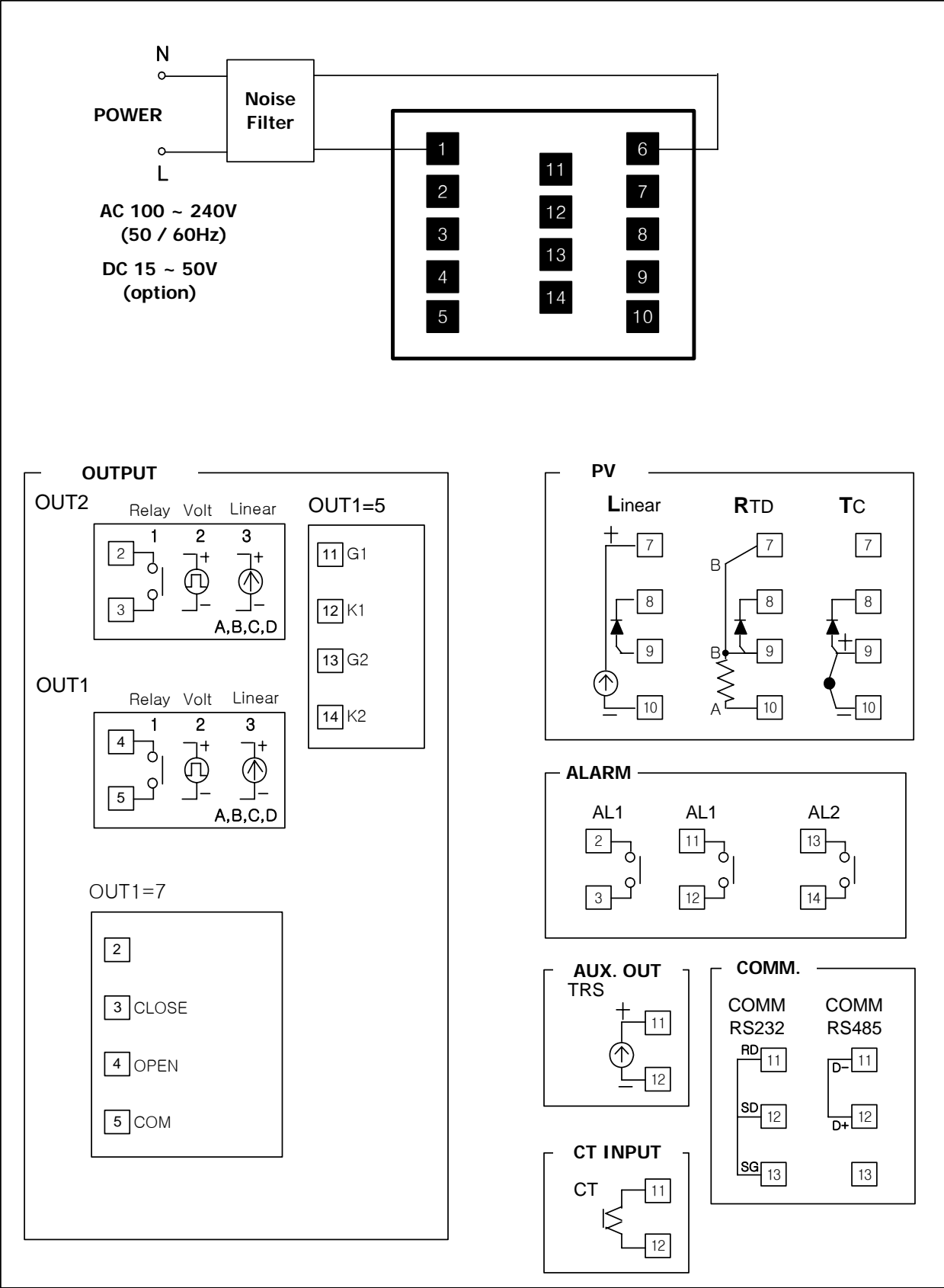

Picture 1-3

Wiring Diagram - DC1020

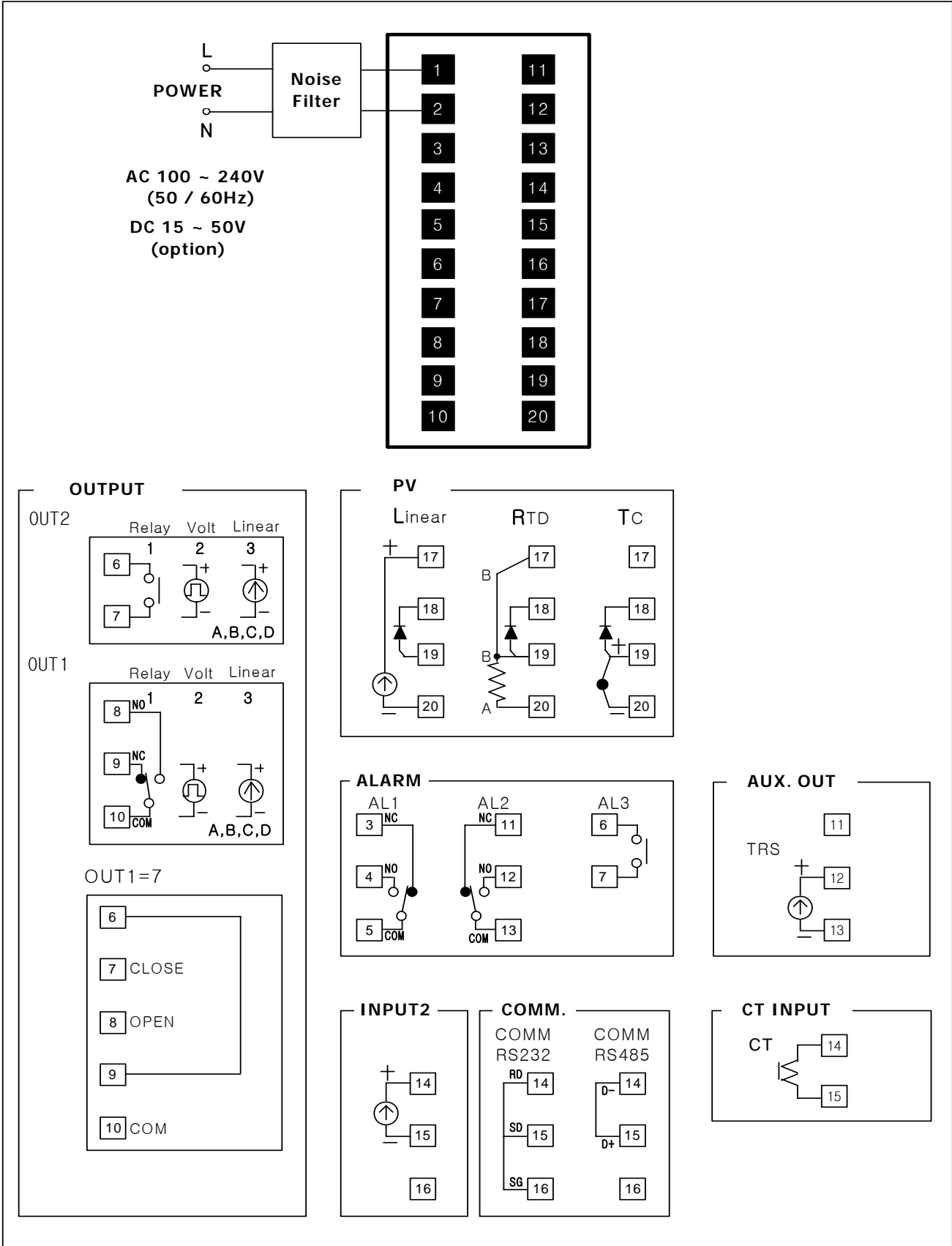

Picture 1-4

## Wiring Diagram - DC1030

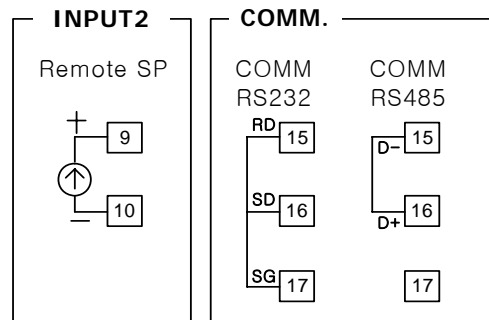
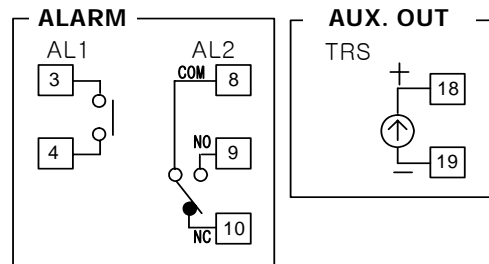
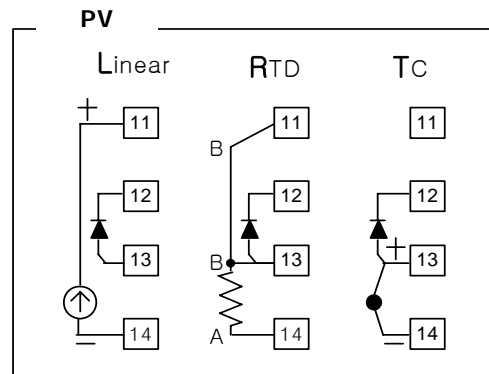
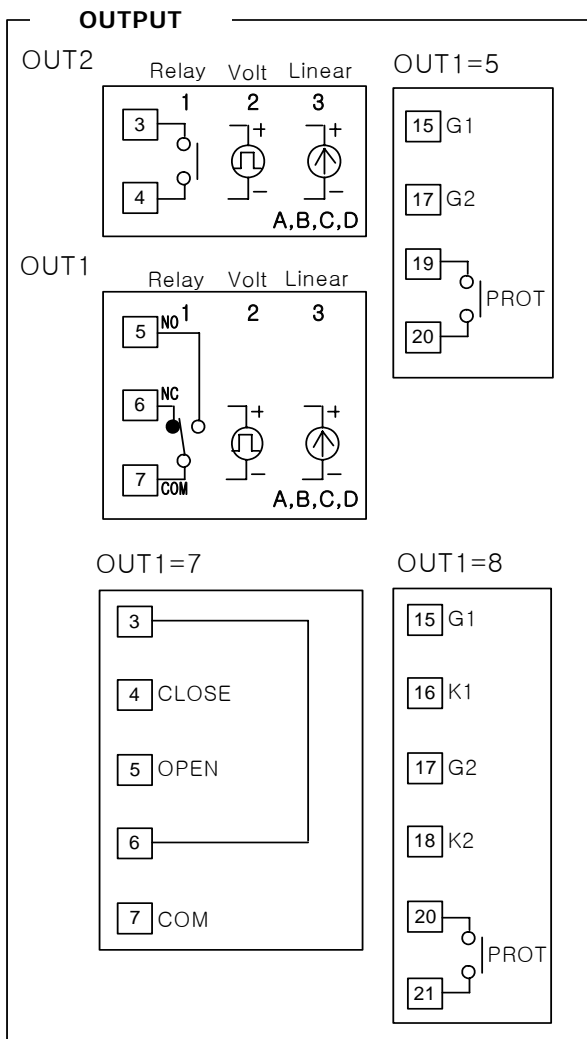
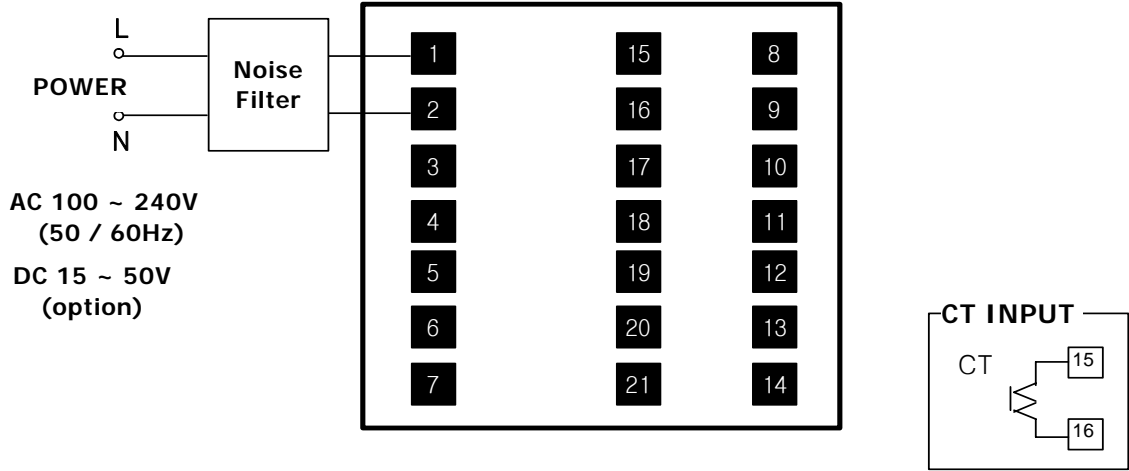

Picture 1-5

## Wiring Diagram - DC1040

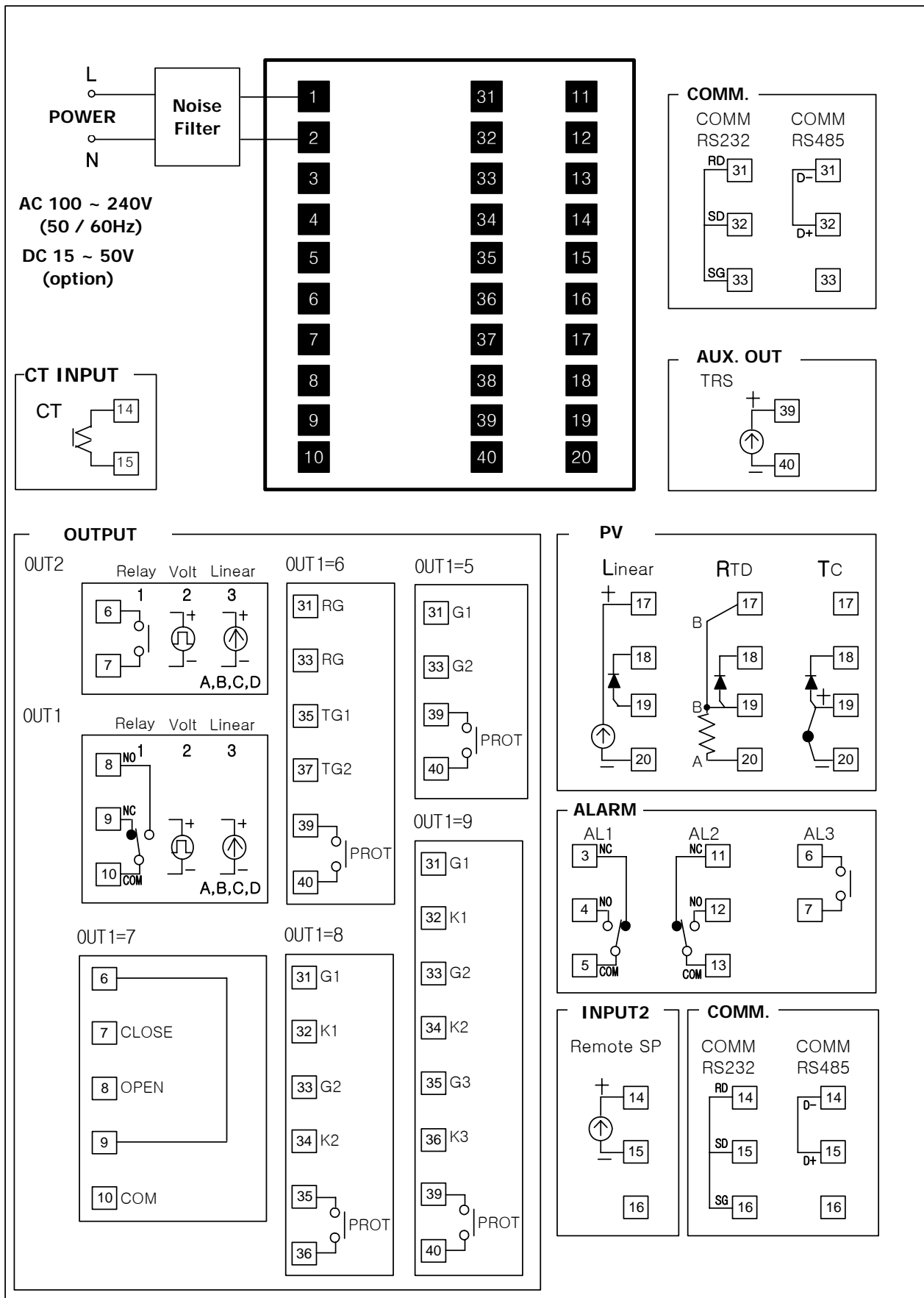

## Model Interpretation

### DC1000 Digital Controller

#### Instructions

- Select the desired Key Number. The arrow to the right marks the selections available.
- Make one selection each from Tables I through III using the column below the proper arrow.
- A dot (\*) denotes unrestricted availability. A letter denotes restricted availability.

#### Key Numbers

DC10\_ \_ \_ \_ - [ I ] - [ II ] - [ II ]

#### KEY NUMBER

Description		Selection	Availability			
<b>Size</b>	48 x 48 mm (DIN 1/16)	DC101_ _ _	↓			
	48 x 96 mm (DIN 1/8)	DC102_ _ _		↓		
	72 x 72 mm	DC103_ _ _			↓	
	96 x 96 (DIN 1/4)	DC104_ _ _				↓
<b>Power &amp; Approvals</b>	90-240 Vac Power / CE	DC10_0_ _	*	*	*	*
	15-50 Vdc Power / CE	DC10_1_ _	b	b	b	b
	90-240 Vac Power / IP 65 / CE	DC10_2_ _	*	*	*	*
	15-50 Vac Power / IP65 / CE	DC10_3_ _	b	b	b	b
	90-240 Vac Power / IP65 / CE / UL Agency Approval	DC10_4_ _	*	*	*	*
15-50 Vdc Power / IP65 / CE / UL Agency Approval	DC10_5_ _	b	b	b	b	
<b>Program</b>	None	DC10_ _C_	*	*	*	*
	Program (2 patterns, 8 segments per 1 pattern)	DC10_ _P_	*	*	*	*
<b>Input</b>	RTD	DC10_ _ _R	*	*	*	*
	TC	DC10_ _ _T	*	*	*	*
	Linear	DC10_ _ _L	*	*	*	*

#### TABLE I

<b>Control Output 1</b>	None	0_ _	*	*	*	*
	Relay, Contact, SPDT, 3A / 240 VAC	1_ _	*	*	*	*
	Volt, Voltage Pulse, 20VDC / 20 mA	2_ _	*	*	*	*
	mA Current, 4-20mA	3_ _	*	*	*	*
	Three Position Step Motor Control	7_ _		c	d	c
	0-5 V	A_ _	*	*	*	*
	0-10 V	B_ _	*	*	*	*
	1-5 V	C_ _	*	*	*	*
	2-10 V	D_ _	*	*	*	*
<b>Control Output 2 (Heat/Cool)</b>	None	_0_	*	*	*	*
	Relay, Contact, SPDT, 3A / 240VAC	_1_	*	*	*	*
	Volt, Voltage Pulse, 20VDC / 20mA	_2_	*	*	*	*
	mA Current, 4-20mA	_3_	*	*	*	*
	0-5V	_A_	*	*	*	*
	0-10V	_B_	*	*	*	*
<b>Alarm Event &amp; Heat Break Alarm</b>	1 Alarm Relay	_ _1	e	*	i	*
	2 Alarm Relays	_ _2	f	g	j	*
	3 Alarm Relays	_ _3		h		k
	HBA	_ _A	e'	p	i'	*
	HBA + 1 Alarm Relay	_ _B		g'	j'	*
HBA + 2 Alarm Relay	_ _C		h'		k'	

\* HBA is available only in case OUT1=1 or OUT1=2.

Availability

DC10\_ \_ \_ \_ 10 20 30 40

**Table II**

		Selection				
<b>Transmitter</b>	None	0 _ _	•	•	•	•
	4-20 mA	1 _ _	•	•	•	•
	0-20 mA	2 _ _	•	•	•	•
	0-5 V	A _ _	•	•	•	•
	0-10 V	B _ _	•	•	•	•
	1-5 V	C _ _	•	•	•	•
	2-10 V	D _ _	•	•	•	•
<b>Remote SP</b>	None	_ 0 _	•	•	•	•
	4-20 mA	_ 1 _				
	0-20 mA	_ 2 _				
	0-5 V	_ A _				
	0-10 V	_ B _				
	1-5 V	_ C _				
	2-10 V	_ D _				
<b>Communication</b>	None	_ _ 0	•	•	•	•
	RS-232	_ _ 1	m	n	•	•
	RS-485	_ _ 2	m	n	•	•
	RS-232 (Modbus rtu)	_ _ A	m	n	•	•
	RS-485 (Modbus rtu)	_ _ B	m	n	•	•

**TABLE III**

<b>Manual</b>	English	E	•	•	•	•
	Chinese	C				
	French	F				
	Korean	K	•	•	•	•

**RESTRICTIONS / NOTES**

Restriction Letter	Available Only With		Not Available With	
	Table	Selection	Table	Selection
b			II	X _ _
c	I	_ 0 1, _ 0 2		
d	I & II	DC10_ _ _ _ - _ 0 1 - _ 0 _ - _		
e, e'			I & II	DC10_ _ _ _ - X _ - _ 1 - _ DC10_ _ _ _ - X _ - _ A - _
e'			I	_ X _
f			I & II	DC10_ _ _ _ - X _ - X _ - _ DC10_ _ _ _ - X _ - _ X - _
g, g'	I		I & II	DC10_ _ _ _ - X _ - X _ - _
g'			II	X X _
h, h'	I & II	DC10_ _ _ _ - _ 0 - _ 0 _ 0 - _	II	_ X _
h'			II	_ X _
i, i'			I & II	DC10_ _ _ _ - X _ - _ X _ - _
i'			II	X _ X
j, j'	I & II	DC10_ _ _ _ - _ 0 - _ 0 _ - _		
j'			II	X _ X
k, k'	I	_ 0 _		
k'			II	_ X _
l				DC10_ _ _ _ P
m			II	X _ _
n			II	X X _
p			II	_ X _

\* X : Option Selected

0 : Option Not Selected

---

## Warranty / Remedy

---

Honeywell warrants goods of its manufacture as being free of defective materials and faulty workmanship. Contact your local sales office for warranty information. If warranted goods are returned to Honeywell during the period of coverage, Honeywell will repair or replace without charge those items it finds defective. The foregoing is Buyer's sole remedy and is **in lieu of all other warranties, expressed or implied, including those of merchantability and fitness for a particular purpose**. Specifications may change without notice. The information we supply is believed to be accurate and reliable as of this printing. However, we assume no responsibility for its use.

While we provide application assistance personally, through our literature and the Honeywell web site, it is up to the customer to determine the suitability of the product in the application.

---

*Specifications are subject to change without notice.*

---

### **Honeywell Process Solution**

IM&C Asia Pacific  
Honeywell Building  
17 Changi Business Park Central 1  
Singapore 486073

**Honeywell**

[www.honeywell.com/imc](http://www.honeywell.com/imc)