



System Installation Guide

THX9321 Prestige® 2.0 ***THX9421 Prestige® IAQ 2.0 with EIM***

With wireless accessories

Control for up to 4 Heat/2 Cool heat pump systems or up to 3 Heat/2 Cool conventional systems for residential and commercial applications.

Installation guide for:

- Prestige THX9321/9421 thermostat
- Equipment Interface Module (EIM)
- Portable Comfort Control
- Wireless Outdoor Sensor
- Wireless Indoor Sensor
- RedLINK™ Internet Gateway

Quick start guide

1	Install thermostat	page 3
2	Install optional Equipment Interface Module (EIM).....	3
3	Power optional accessories	4
4	Link thermostat to wireless network	5
5	Link optional accessories to wireless network	6
6	Install optional sensors	7
7	Setup installer options	8
	Wiring guides.....	10-17
	Key features.....	18-25
	Device replacement and specifications	26-27

⚠ DISCONNECT POWER BEFORE INSTALLATION. Can cause electrical shock or equipment damage.

MERCURY NOTICE: If this product is replacing a control that contains mercury in a sealed tube, do not place the old control in the trash. Contact the Thermostat Recycling Corporation at www.thermostat-recycle.org or 800-238-8192 for information on how and where to properly and safely dispose of your old thermostat.

Must be installed by a trained, experienced technician. Read these instructions carefully. Failure to follow these instructions can damage the product or cause a hazardous condition.

Your Honeywell advantage

RedLINK™ Compatible

Increase your content and profit per job by including RedLINK™ accessories that meet your customers' comfort and convenience needs. RedLINK accessories include the Wireless Outdoor Sensor, Portable Comfort Control (PCC), Equipment Interface Module (EIM), RedLINK Internet Gateway, Wireless Indoor Sensor, TrueSTEAM™ humidifier with Wireless Adapter, TrueZONE™ zoning panel with Wireless Adapter, Vent Boost Remote and Entry/Exit Remote.

Customizable Service Reminders

Set up to 10 service reminders. Choose from the pre-set options or customize your own. Reminders based on date, outdoor temperature or a dry contact input will alert customers with instructions to contact you for assistance.

Delta T Alerts and Diagnostics

Alerts give customers a sense of security while also enabling you to service or replace the equipment prior to a loss of heating or cooling. Based on limits you set at installation, customers can be alerted when their system is not operating as expected. The system alert will instruct customers to contact you for assistance. Requires EIM.

Delta T Installer Test

Save time by viewing Delta T while running a system test to verify proper operation. Requires EIM.

Universal Inputs – S1 and S2

Assignable inputs allow you to configure Indoor and Outdoor Temperature Sensors, Discharge and Return Air Sensors or Dry Contact Devices. Dry Contact Devices can be used to trip pre-set or customized alerts on the thermostat home screen. Requires EIM.

User Interactions Log

The interaction log stores history of thermostat setting changes including temperature, system and installer setup. You can use the interaction log to save time by determining if the issue is a system error or an accidental user error.

Configurable for Residential and Light Commercial Applications

One thermostat does it all to meet the needs of Residential and Light Commercial applications. Simply select Residential or Commercial during the installer setup. If Commercial is selected, the thermostat will use commercial language, meet building codes and offer 365 day holiday scheduling.

USB Port for Quick Installer Setup

Save time by using a USB stick to upload installer settings and service reminders in one simple step.

Selectable Sensors

When paired with a Wireless Indoor Sensor(s) you have the ability to choose which sensor(s) to use for temperature, humidification and dehumidification. They can be used in combination for temperature averaging—or individually—to condition humidity levels in separate spaces.

1 Install thermostat

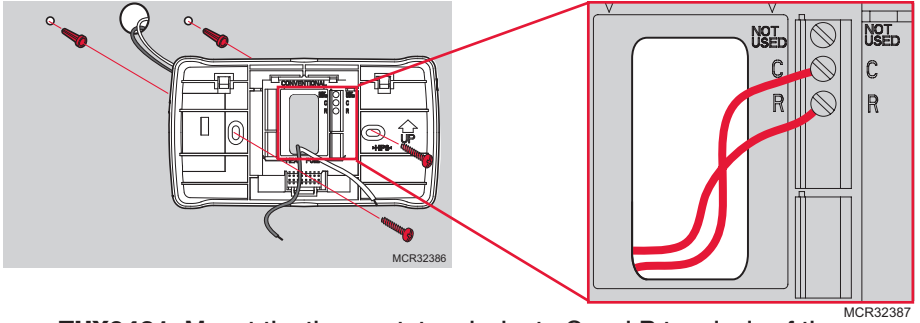

- **THX9421:** Mount the thermostat and wire to C and R terminals of the Equipment Interface Module (EIM), or to a separate 24 volt transformer (not provided).
- **THX9321:** Install and wire as above if using EIM. If not, see pages 13-15.

i When the THX9321 thermostat is used with the EIM, the relays in the thermostat do not function.

See pages 10-17 for detailed wiring guidelines

2 Install Equipment Interface Module (if used)

[If no EIM is used, skip to Section 3.]

Use screws & anchors as appropriate for the mounting surface. Mount the EIM near the HVAC equipment, or on the equipment itself.

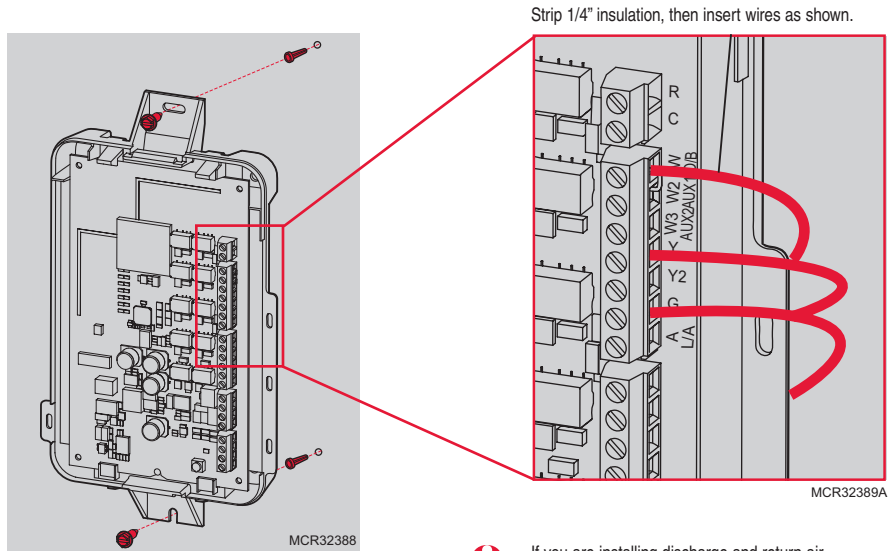

NOTE: If you install more than one thermostat and EIM, the EIMs must be at least 2 feet apart.

i If you are installing discharge and return air sensors, refer to the mounting instructions in the Alerts and Delta T Diagnostics Installation Instructions packed with the Prestige IAQ 2.0 kit.

3 Power optional accessories

[If no wireless accessories are used, skip to Section 4.]

Wireless Outdoor Sensor Wireless Indoor Sensor Portable Comfort Control

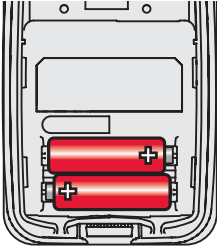

MCR32937

Install 2 fresh AA **lithium** batteries

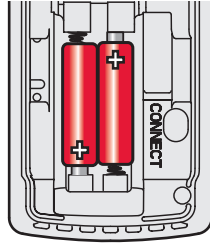

MCR32938

Install 2 fresh AAA alkaline batteries

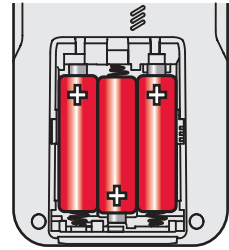

MCR32939

Install 3 fresh AA alkaline batteries

RedLINK™ Internet Gateway

The Honeywell RedLINK Internet Gateway gives your customers remote access to home climate-control systems from any location with Internet access.

Using a Web browser, users can review and adjust indoor temperature, system mode and other settings. The Gateway can also send alerts to as many as 6 email addresses if a problem occurs.

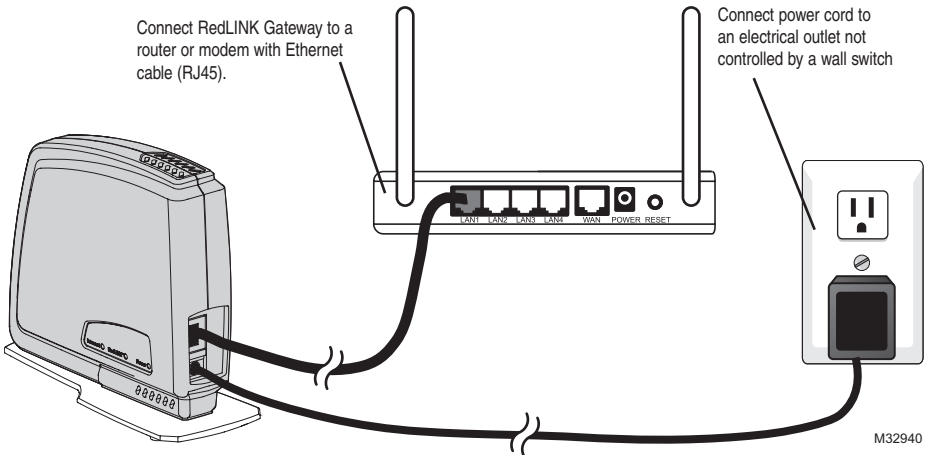

4 Link thermostat to the wireless network (if used with an EIM or TrueZONE Wireless Adapter)

Next, link all components and RedLINK™ accessories to the wireless network.

Initial powerup

When the thermostat is first activated, it will lead you through the steps necessary to define and set up your system. The steps will change depending on the type of system and thermostat you're installing.

Setup options for THX9321

- If non-zoned system:
- Setup for thermostat only
 - Setup for use with EIM

- If zoned system:
- Setup for EIM wired to zone panel
 - Setup for thermostat wired to zone panel
 - Setup for RedLINK wireless connection to zone panel (using THM4000 TrueZONE Wireless Adapter)

Setup options for THX9421

- If non-zoned system:
- Setup for EIM connection

- If zoned system:
- Setup for EIM wired to zone panel
 - Setup for RedLINK wireless connection to zone panel (using THM4000 TrueZONE Wireless Adapter)

Link thermostat to EIM or TrueZONE® Wireless Adapter

Use the step-by-step thermostat menus to define your system type (above). When you reach the Wireless Setup screen, follow the steps below:

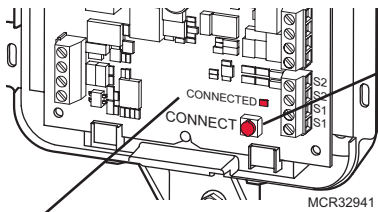

Press and release the **CONNECT** button at the EIM or Wireless Adapter, and make sure the "Connected" light is flashing green.

If the "Connected" light does not flash, make sure no other RedLINK devices are in Wireless Setup mode, then try again.

 If the power light at the wireless adapter does not turn on, consult the TrueZONE manual for help.

"Connected" status light

- **Green flashing:** In Wireless Setup mode.
- **Green steady:** RedLINK device(s) are communicating.
- **Red:** RedLINK device(s) not communicating. Check EIM and RedLINK devices.



While the EIM light is flashing, press **NEXT** to link the thermostat with the EIM. After a brief delay, the screen will display "Device Connected."

 At any screen you can press **HELP** for more information, or press **BACK** to change earlier options.

5 Link optional accessories to wireless network

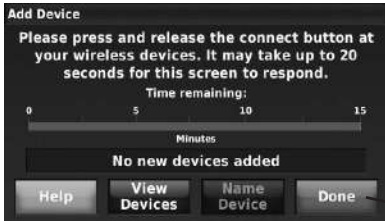

While the Add Device screen is displayed on the thermostat, **press and release the CONNECT** button on each wireless device, as described below. Accessories need to be at least 2 feet away from the thermostat or EIM during the linking process.

Press **DONE** after all devices have been linked

i If you need to return to the "Add Device" screen to add devices later, press **MENU** and scroll down to press **INSTALLER OPTIONS**. Enter the date code (password) when prompted. The date code is printed on the back of the thermostat; or press **MENU > EQUIPMENT STATUS** to find the date code. After you enter the password, scroll down to press **WIRELESS DEVICE MANAGER** and then select **ADD DEVICE**.

Wireless outdoor sensor

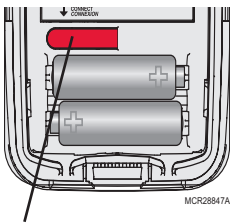

Press and release **CONNECT**. After a short delay the thermostat will display "Wireless Outdoor Sensor added" on the Add Device screen.

Wireless indoor sensor

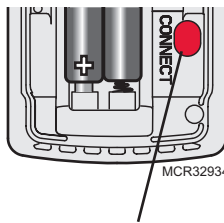

Press and release **CONNECT**. After a short delay, the status light will glow green for 15 seconds.

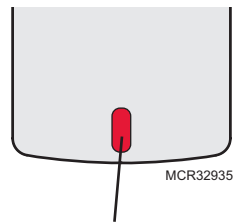

If the status light turns red, the sensor did not link with the thermostat.

In normal operation, this light remains off. If it begins flashing red, batteries are low (power will be depleted after 2–3 weeks).

Portable Comfort Control



Press **CONNECT** on the Portable Comfort Control display screen. Press **DONE** when the screen displays "Connected," then exit or continue to link another thermostat.

Error messages:

- E1 29** Incompatible device cannot be connected.
- E1 34** Low RF signal. Move device to a different location and try again.
- E1 38** Make sure the thermostat or the EIM is in Wireless Setup mode, and the Portable Comfort Control is at least 2 feet away (600 mm).

i The linking procedure will time out if there is no keypress for 30 minutes. To begin again, **press and hold** in the lower right corner of the screen until the display changes (about 3 seconds).

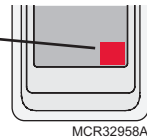

RedLINK Internet Gateway

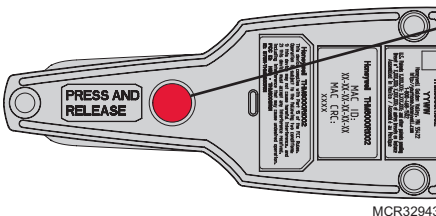

Press and release the button on the bottom of the Internet Gateway. After a short delay, the RedLINK status light will glow steady green.

i The Internet Gateway must be registered online before use at www.mytotalconnectcomfort.com. Enter the MAC ID and MAC CRC numbers located on the bottom of the Internet Gateway. For additional information, see instructions provided with the device.

6 Install optional sensors

[If no sensors are used, skip to Section 7.]

To install outdoor air sensor

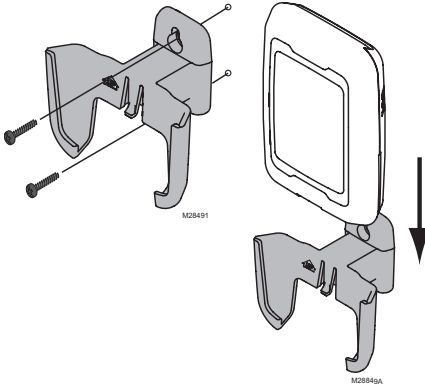

- 1 Mount the sensor on a vertical exterior wall, at least 6 inches below any overhang. Choose a location protected from direct sunlight.
- 2 Place sensor securely in bracket, facing away from wall.

To install indoor air sensor

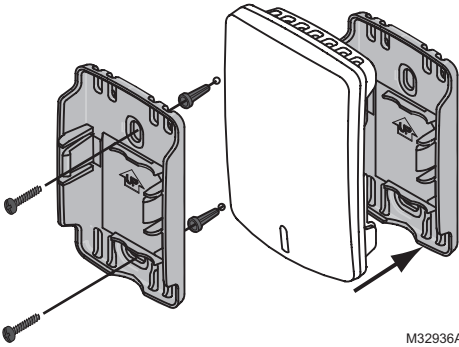

- 1 Remove the wallplate and mount it 4 to 6 feet above the floor on an interior wall. Drill 3/16-inch holes for drywall, 7/32-inch for plaster.
- 2 Attach sensor securely to wallplate as shown.

7 Setup Installer options (ISU)

To setup the thermostat, press **MENU** and scroll down to press **INSTALLER OPTIONS**. Enter the date code (password) when prompted. The date code is printed on the back of the thermostat; or press **MENU > EQUIPMENT STATUS** to find the date code. After you enter the password, press **CREATE SETUP** to setup the thermostat.

A brief summary of installer options follows (pages 8–9). You can download a complete list of all options at <http://customer.honeywell.com>.

7 Setup Installer options (ISU) - continued



- Create Setup:** Press **CREATE SETUP** to set all system settings one by one.
- View/Edit Current Setup:** Press **VIEW/EDIT CURRENT SETUP** to select a specific function and make quick changes.
- Set Up Diagnostics:** Press **SET UP DIAGNOSTICS** to setup and test Delta T diagnostics.
- Installer Test:** Press **INSTALLER TEST** to quickly determine if the heat, cool, fan and thermostat are operating properly. Minimum off timers are ignored during the test.
- Data Logs:** Press **DATA LOGS** to view the Alerts Log and User Interactions Log.
- Wireless Device Manager:** Press **WIRELESS DEVICE MANAGER** to add or remove wireless accessories.
- Advanced Options:** Press **ADVANCED OPTIONS** to setup the thermostat using a USB device or to restore the thermostat to the factory default settings.

i TIP: You can use the thermostat USB port to download all system configuration and installer options, including your company name and contact information. You can upload this data to each thermostat you install, to save time.

R: Residential C: Commercial B: Both

Thermostat functions marked in gray below require an EIM (see page 3).

ISU	Function	ISU	Function
1000	Language	B	3200-3220 Heating Derivative, Integral, Throttling range
1010	Residential/Commercial	B	3240 Minimum Compressor Off Time
1020	Zone Number	B	3260 Extended Fan Run Time in Cool
1030	Device Name	B	3260 Extended Fan Run Time in Heat
1030	Device Name on Home Screen	C	4000 Number of Scheduled Periods
1040	Programmable/Non-programmable	B	4010 Pre-occupancy Purge Duration
1050	Fahrenheit/Celsius	B	4020 Override: Standard or Initiate Occupancy
1060	Outdoor Air Sensor	B	4030 Override Duration
2000	Heating System Type	B	4050 Minimum Recovery Settings - Heat
2010	Heating Equipment Type	B	4060 Maximum Recovery Settings - Heat
2020-2100	Heat Stages	B	4070 Minimum Recovery Settings - Cool
2050	Geothermal Forced Air System	B	4080 Maximum Recovery Settings - Cool
2060	Reversing Valve O/B	B	4090 Adaptive Intelligent Recovery
2070-2090	Cool/Compressor Stages	B	4100 Minimum Cool Setpoint
2110	Fan Operation in Heat	B	4100 Maximum Heat Setpoint
2120, 2180	Backup Heat Type	B	4110 Keypad Lockout
2130, 2170	Backup Heat Stages	B	4120 Entry/Exit Remote - Home/occupied Cool Setpoint
2150, 2200	Backup Heat Operation	B	4120 Entry/Exit Remote - Home/occupied Heat Setpoint
2160, 2210	Backup Heat Fan Operation	B	4130 Entry/Exit Remote - Away/unoccupied Cool Setpoint
2190	External Fossil Fuel Kit	B	4130 Entry/Exit Remote - Away/unoccupied Heat Setpoint
2220	A-L/A Terminal Setup	C	4140 Entry/Exit Remote - Vacation/holiday Cool Setpoint
3000	Manual/Auto Changeover	B	4140 Entry/Exit Remote - Vacation/holiday Heat Setpoint
3000	Auto Changeover Deadband	B	5000 Select Wired Sensors
3010	Temperature Control Options	B	5010 Indoor Temperature Sensor Name
3020	Finish With High Cool Stage	B	5020 Terminals Wired to Indoor Sensor
3021	Finish With High Heat Stage	B	5030 Indoor Temperature Sensor Type
3030	Staging Control - Cool Differentials	B	5040 Indoor Sensors Used for Temperature Control
3040-3060	Staging Control - Heat Differentials	B	5050 Terminals Wired to Outdoor Sensor
3080, 3090	Staging Control - Backup Heat Differentials	B	5070 Terminals Wired to Return Air Sensor
3110	Backup Heat Upstage Timer	B	5080 Return Air Sensor Type
3120	Outdoor Compressor Lockout	B	
3120	Outdoor Backup Heat Lockout	B	
3130, 3150	Heat Cycles Per Hour	B	
3140	Cool Cycles Per Hour	B	
3160	Backup Heat Cycles Per Hour	B	
3170-3190	Cooling Derivative, Integral, Throttling range	C	

7 Installer options (ISU) - continued





Thermostat functions marked in gray below require an EIM (see page 3).

ISU	Function	ISU	Function
5090	Terminals Wired to Discharge Air Sensor	B	9120 System Modes Allowing Dehumidification
5100	Discharge Air Sensor Type	B	9130 Dehumidifier Fan Control
5110	A-Coil Low Temperature Cutoff	B	9140 Dehumidifier Lockout
6000	Select the Dry Contacts in the System	B	9180 Dehumidification Away Mode
6010	Terminals Wired to Remote Setback Dry Contact	C	9190 Dehumidification Away Mode - Fan Control
6020	Remote Setback Dry Contact Setup	C	9200 Dehumidification Away Mode - Low Limit Temperature
6030	Remote Setback Time Delay	C	9200 Dehumidification Away Mode - Temperature Setting
6040	Remote Setback - Standby Cool Setpoint	C	9200 Dehumidification Away Mode - Dehumidification Setting
6040	Remote Setback - Standby Heat Setpoint	C	9210 Dehumidifier Filter Replacement Reminder
6050	Terminals Wired to Full Drain Pan Alert Dry Contact	B	10000 Ventilation Type
6060	Full Drain Pan Alert Dry Contact Setup	B	10020 Terminals Wired to Ventilator/Fresh Air Damper
6070	Terminals Wired to Dirty Filter Alert Dry Contact	B	10050 Ventilation Control Method
6080	Dirty Filter Alert Dry Contact Setup	B	10060 Ventilation Fan Control
6090	Terminals Wired to Water Leak Alert Dry Contact	B	10090 Number of Bedrooms
6100	Water Leak Alert Dry Contact Setup	B	10090 Size of House
6110	Terminals Wired to System Shutdown Alert Dry Contact	B	10100 Enter Equipment Ventilation Rate
6120	System Shutdown Alert Dry Contact Setup	B	10120 Ventilation Percent On Time
6130	Terminals Wired to Service Needed Alert Dry Contact	B	10125 Ventilation Priority
6140	Service Needed Alert Dry Contact Setup	B	10130 Ventilation Low Temperature Lockout
6150	Terminals Wired to Fan Failure Alert Dry Contact	B	10130 Ventilation High Temperature Lockout
6160	Fan Failure Alert Dry Contact Setup	B	10130 Ventilation High Dewpoint Lockout
6170	Terminals Wired to Custom Alert Dry Contact	B	10140 Lockout Ventilation on Hum/Dehum Calls
6180	Custom Alert Dry Contact Setup	B	10160 Ventilate on High Indoor Humidity
6190, 6200	Custom Alert Name and Message	B	10170 Ventilator Core Cleaning Reminder
7000	Filter Type	B	10170 Ventilator Filter Cleaning Reminder
7020	Number of Air Filters	B	11000 Number of UV Devices
7110	Air Filter Replacement Reminder	B	11050 UV Bulb Replacement Reminder
7110	Air Filter 2 Replacement Reminder	B	11050 UV Bulb 2 Replacement Reminder
7120	EAC Cell Cleaning Reminder	B	12000 Installer Custom Reminders
7120	EAC Pre-Filter Cleaning Reminder	B	13000 Heat Delta T Diagnostics
7120	EAC Post-Filter Replacement Reminder	B	13010 Cool Delta T Diagnostics
8000	Humidifier Type	B	13015 Set Advanced Delta T Diagnostic Options
8010	Indoor Sensor Used for Humidification Control	B	13020 Allow Delta T Diagnostics During Humidification
8030	Terminals Wired to the Humidifier	B	13030 Allow Delta T Diagnostics During Dehumidification
8050	Humidification - Window Protection	B	13040 Allow Delta T Diagnostics During Ventilation
8060	System Modes Allowing Humidification	B	13050-13080 Allow Heat Delta T Diagnostics: Temp & Humidity
8070	Humidification Control	B	13090-13120 Allow Backup Heat Delta T Diagnostics: Temp & Humidity
8080	Humidifier Lockout	B	13130-13160 Allow Cool Delta T Diagnostics: Temp & Humidity
8100	Clean Tank / Water Filter Replacement Reminder	B	13170 Defrost Cycle
8100	Humidifier Pad Replacement Reminder	B	13180 Delta T Alert Sensitivity
9000	Dehumidification Equipment	B	13190 Display Delta T Alerts to User
9010	Indoor Sensor Used for Dehumidification Control	B	14000 Clock Format
9020	Humidity Sensor Displayed on the Home Screen	B	14010 Daylight Saving Time
9040	Terminals Wired to Dehumidification Equipment	B	14020 Indoor Temperature Display Offset
9050	A/C with Low Speed Fan Setup	B	14020 Indoor Humidity Display Offset
9050	Hot Gas Bypass Setup	C	15000-15020 Dealer name, phone, email, website, message
9070	Dehumidification - Overcooling Limit	R	
9080	Dehumidification Control	C	
9090	Dehumidification Minimum On Time	C	
9100	High Humidity Comfort Reset Setting	C	

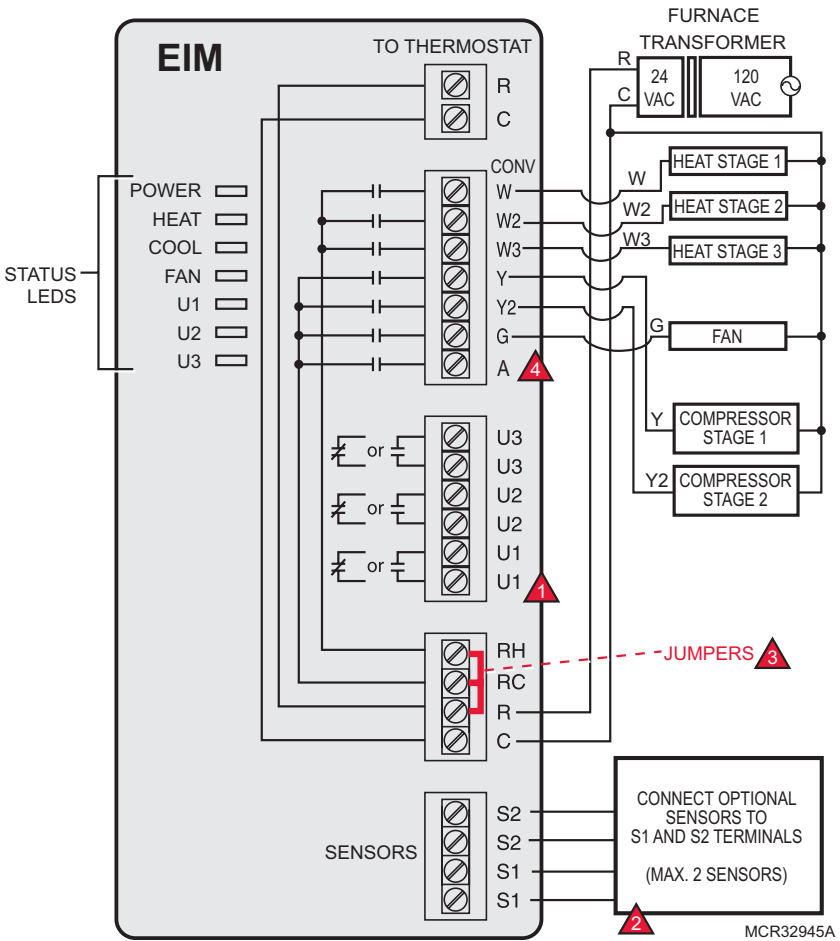
EIM wiring guide – conventional systems

Typical wiring of a conventional system with up to 3-stage heat and 2-stage cool with one transformer.



-  See guides on following pages for thermostat wiring and geothermal radiant heat wiring.
-  Wire a maximum of 2 sensors using the S1 and S2 terminals. See ISU 5000-6190 for options. S1 and S2 terminals can be connected to an indoor sensor, outdoor sensor, discharge sensor, return sensor, dry contact device to display an alert or an occupancy sensor for remote setback.
-  Remove jumper(s) if using separate transformers.
-  See Economizer wiring section.
-  See following pages for additional thermostat wiring guidelines for heat pumps, geothermal systems and optional Economizer.

EIM wiring guide — heat pump systems

Typical wiring of a heat pump system with up to four-stage heat and two-stage cool with one transformer.

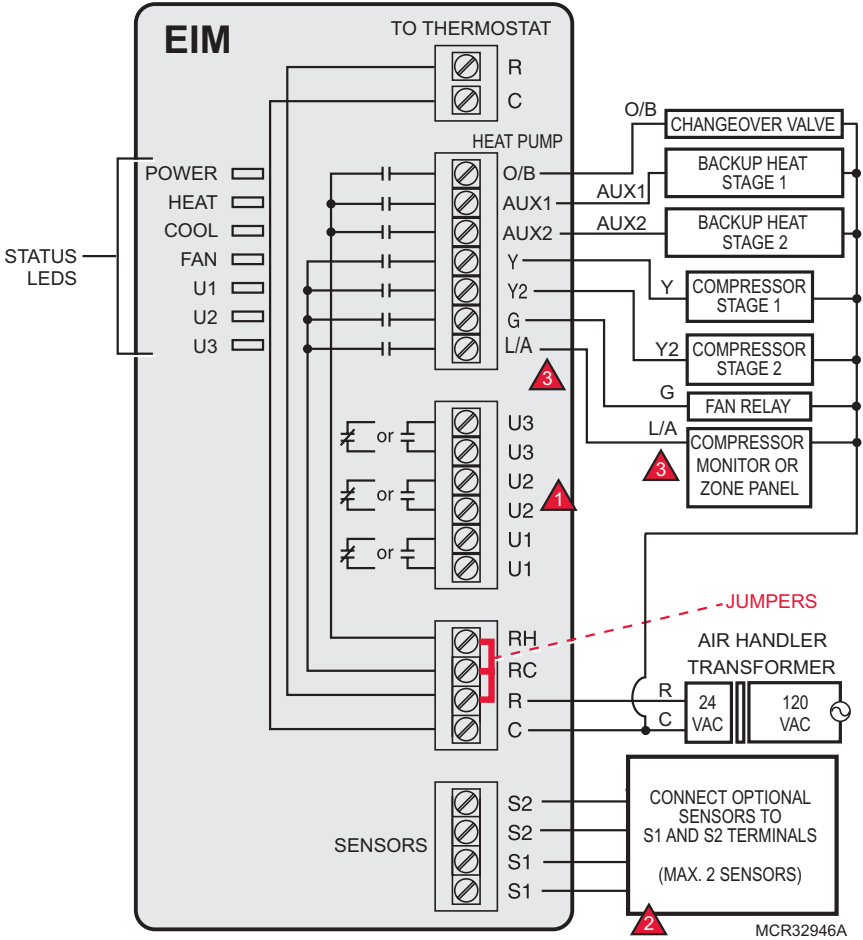

- 1** See guides on following pages for thermostat wiring and geothermal radiant heat wiring.
- 2** Wire a maximum of 2 sensors using the S1 and S2 terminals. See ISU 5000-6190 for options. S1 and S2 terminals can be connected to an indoor sensor, outdoor sensor, discharge sensor, return sensor, dry contact device to display an alert or an occupancy sensor for remote setback.
- 3** L/A terminal sends continuous output when thermostat is set to EM HEAT mode, except when set up for Economizer or TOD. See Economizer wiring section.

EIM wiring guide – geothermal radiant heat

Typical wiring for geothermal radiant heat, geothermal forced-air, and backup heat with one transformer. See page 19 for operation.

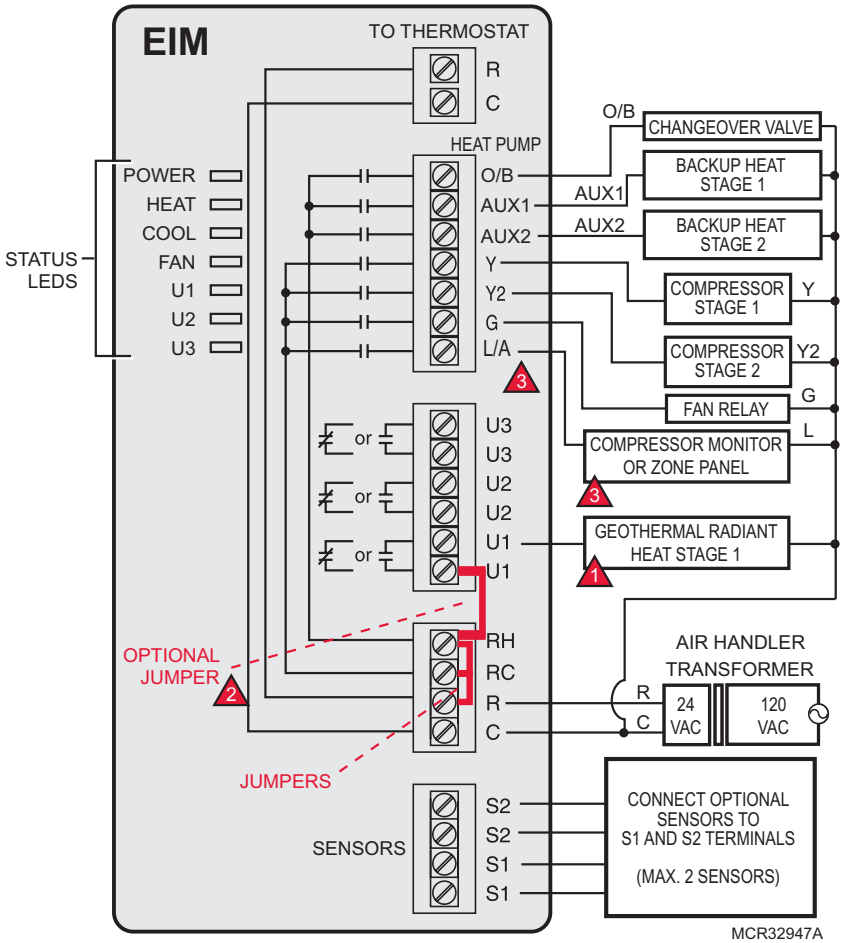

- 1** U1, U2 or U3 terminals must be used for geothermal radiant heat (ISU 2010). Thermostat allows 2 stages of radiant heat—geothermal (stage 1) and boiler (stage 2).
- 2** "U" terminals are normally open dry contacts when set up for geothermal radiant heat. You must install a field jumper if radiant heat is powered by system transformer. Do NOT install a field jumper if radiant heat has its own transformer.
- 3** L/A terminal sends continuous output when thermostat is set to EM HEAT mode except when set up for Economizer or TOD. See Economizer wiring section.

Thermostat wiring guides – Prestige THX9321

Typical wiring of a 3-heat / 2-cool heat pump system with one transformer

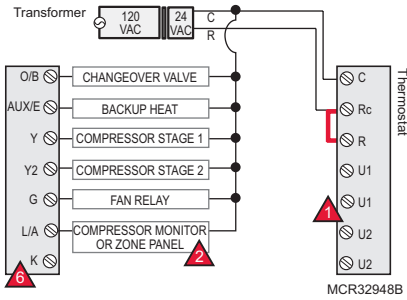

Typical wiring of a 2-heat / 2-cool conventional system with one transformer

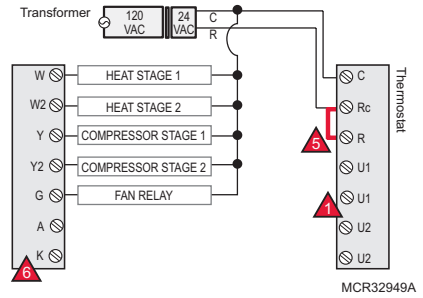

Typical wiring of a 3-heat / 2-cool heat pump system with two transformers (example - oil forced air backup heat)

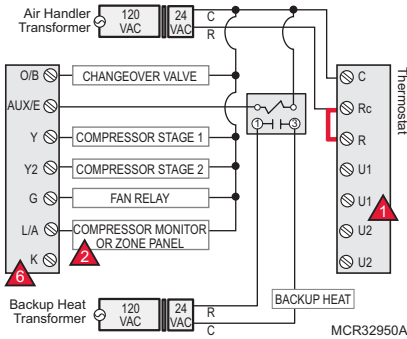

Typical wiring for geothermal radiant heat, geothermal forced-air and backup heat with one transformer. See page 19 for operation.

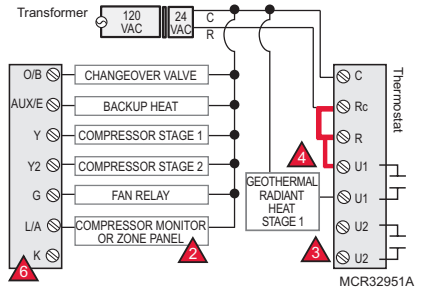

- 1** U1 and U2 terminals are dry contacts.
- 2** L/A terminal sends continuous output when thermostat is set to EM HEAT mode except when set up for Economizer or TOD. See Economizer wiring section.
- 3** U1 or U2 terminals must be used for geothermal radiant heat (ISU 2010). Thermostat allows 2 stages of radiant heat—geothermal (stage 1) and boiler (stage 2).
- 4** "U" terminals are normally open dry contacts when set up for geothermal radiant heat. You must install a field jumper if radiant heat is powered by system transformer. Do NOT install a field jumper if radiant heat has its own transformer.
- 5** Remove jumper if using separate transformers.
- 6** Connect the THP9045 Wiresaver Module to the K terminal in heating/cooling applications that do not have a common wire at the thermostat. The K terminal cannot be used in heat-only applications. See THP9045 installation instructions for more information.

Prestige THX9321 or EIM: Using universal relays to control heating or cooling

Powering universal relay with system transformer (THX9321 shown)

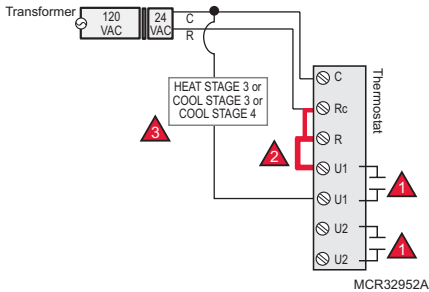

Powering universal relay with separate heating transformer (THX9321 shown)

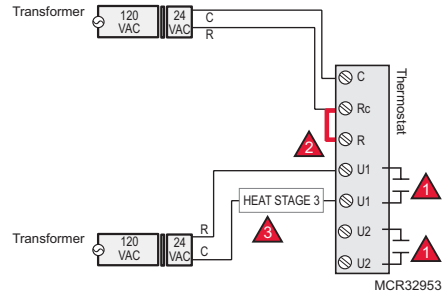

- ▲ 1 U1/U2/U3 terminals are normally open dry contacts when set up for a stage of heating or cooling.
- ▲ 2 You must install a field jumper if the stage of heating or cooling is powered by system transformer. Do NOT install a field jumper if the stage of heating has its own transformer.
- ▲ 3 U1/U2/U3 terminals are assigned to a stage of heating or cooling in the Installer Setup. Options are:

THX9321 Thermostat (U1 and U2)

- Cool Stage 3 (ISU 2080 - commercial only)
- Cool Stage 4 (ISU 2090 - commercial only)
- Conventional Heat Stage 3 (ISU 2100, 2140)
- Backup Heat Stage 2 for Heat Pumps (ISU 2170)
- Geothermal Radiant Heat (see wiring guide on pages 12-13)

THX9421 Thermostat with EIM (U1, U2 and U3)

- Cool Stage 3 (ISU 2080 - commercial only)
- Cool Stage 4 (ISU 2090 - commercial only)
- Geothermal Radiant Heat (see wiring guide on pages 12-13)

Dry Contact Alerts

▲ **EQUIPMENT DAMAGE HAZARD.** Do not apply power to S1 or S2 terminals.

i The dry contact device must be rated for low voltage.

If you are not using the S1 and S2 terminals on the EIM, you can connect them to a dry contact device to display an alert. Dry contact alerts include Full Drain Pan, Dirty Filter, Water Leak, System Shutdown, Service Needed, Fan Failure and Custom Alert (ISU 6000).

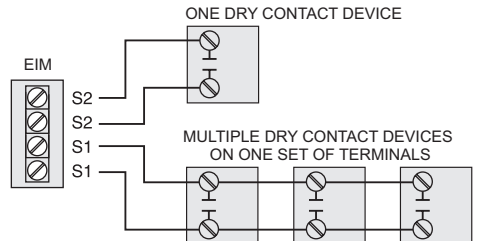

M31488

i You can connect multiple Dry Contact devices in parallel to the S1 or S2 terminals.

Wiring guide – IAQ equipment (EIM or thermostat)

"U" terminals can be used for humidification, dehumidification or ventilation.

With power supply

Typical hookup of powered humidifier.

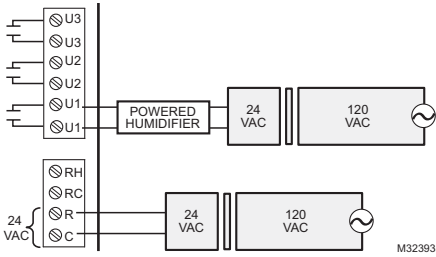

Typical hookup of powered ventilation.

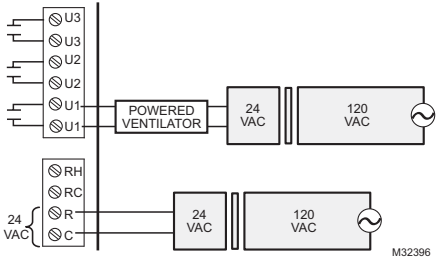

Typical hookup of powered dehumidifier (whole house dehumidifier).

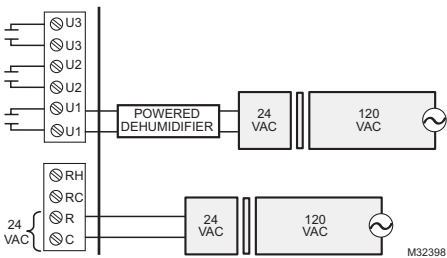

Without power supply

Typical hookup of non-powered humidifier.

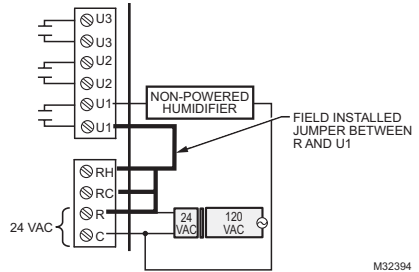

Typical hookup of non-powered ventilation.

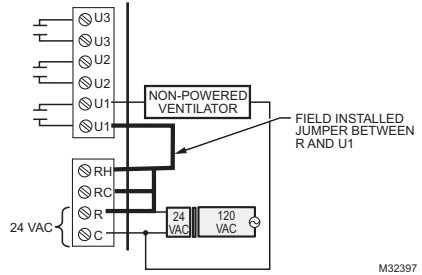

Typical hookup of variable speed blower for dehumidification in low speed.

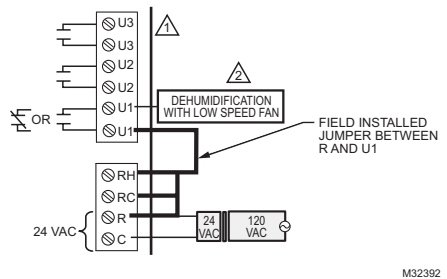

KEY

- ANY COMBINATION OF UNIVERSAL RELAYS (U1, U2, U3) CAN BE USED. THEY ARE SET IN THE THERMOSTAT INSTALLER SETUP.
- WIRE THE THERMOSTAT OR EIM UNIVERSAL RELAY TO THE LOW SPEED FAN FOR DEHUMIDIFICATION CONTROL AT THE EQUIPMENT. THE THERMOSTAT OR EIM RELAY CAN BE SET TO NORMALLY OPEN OR NORMALLY CLOSED IN THE THERMOSTAT INSTALLER SETUP.
- = NORMALLY OPEN, DRY CONTACTS
- = NORMALLY CLOSED, DRY CONTACTS

Economizer Module wiring guides

Typical wiring of a W7220 Economizer Module for a heat pump system, using a Prestige THX9321 thermostat or Equipment Interface Module.

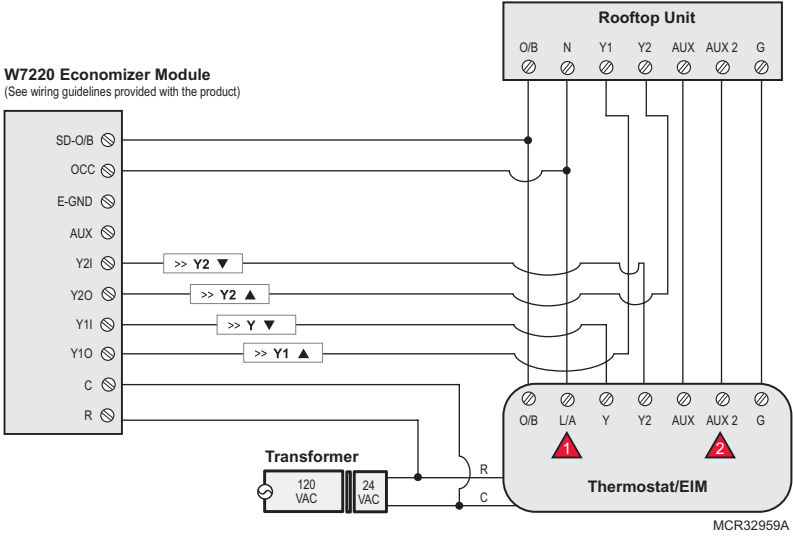

Typical wiring of a W7220 Economizer Module for a conventional system, using a Prestige THX9321 thermostat or Equipment Interface Module.

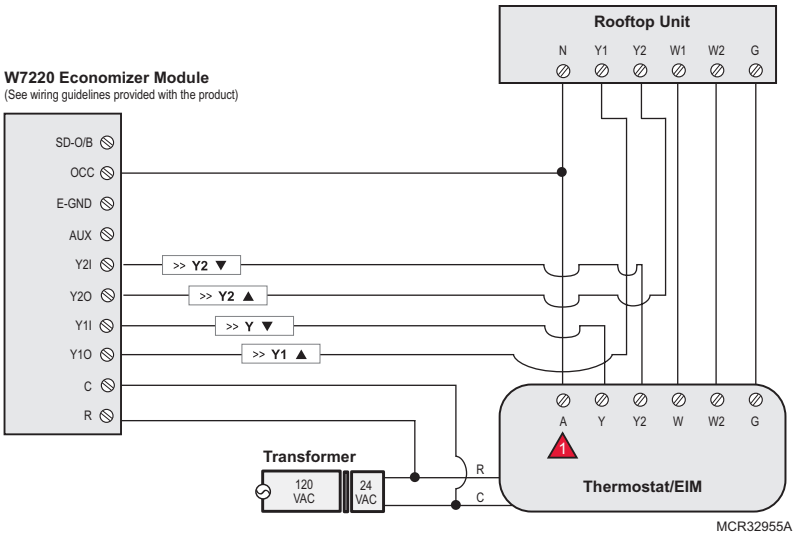

- 1** "A" or "L/A" terminal must be configured for Economizer in the installer setup (ISU 2220). These terminals are powered by the cooling transformer (Rc terminal).
- 2** Terminal AUX 2 is present only on the Equipment Interface Module.

Economizer Module wiring guides

Typical wiring of a W7213/W7214 Economizer Module for a heat pump system, using a Prestige THX9321 thermostat or Equipment Interface Module.

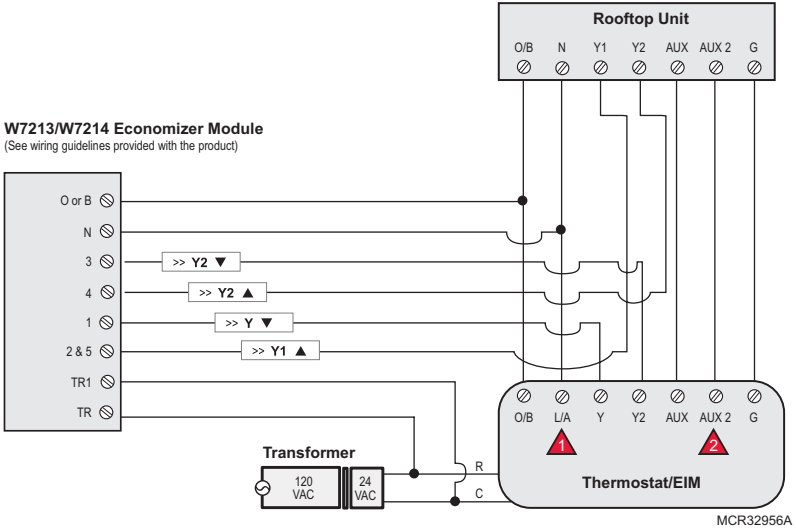

Typical wiring of a W7212 Economizer Module for a conventional heating system, using a Prestige THX9321 thermostat or Equipment Interface Module.

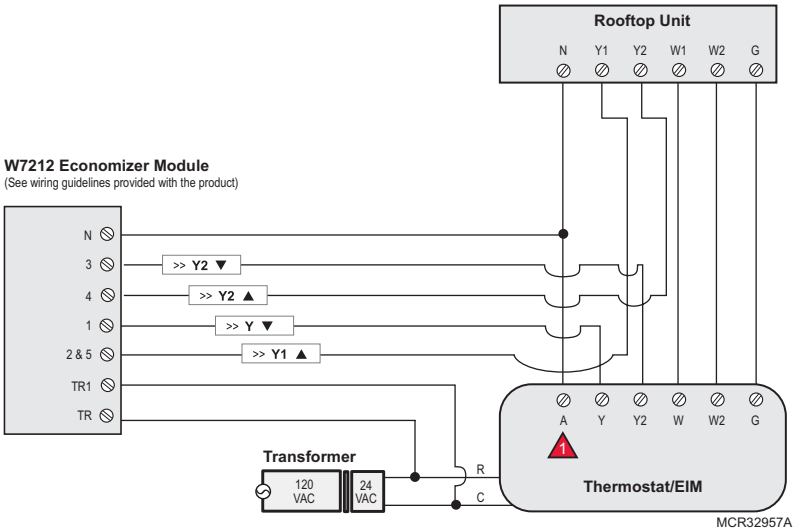

- 1** "A" or "L/A" terminal must be configured for Economizer in the installer setup (ISU 2220). These terminals are powered by the cooling transformer (Rc terminal).
- 2** Terminal AUX 2 is present only on the Equipment Interface Module.

Economizer and TOD operation (ISU 2220)

Commercial use only

The Economizer can greatly reduce energy costs if configured properly. In some climates the cooling system may run hundreds of hours, when it may not be required to maintain indoor comfort. In some conditions, ventilation with outdoor air can achieve the same level of comfort at lower cost. Tables below explain how the Economizer feature maintains comfort while minimizing costs.

Thermostat Mode	Equipment Operation	A-L/A terminal: Economizer
Occupied	Heat/Cool/Fan running	ON
Occupied temporarily	Heat/Cool/Fan running	
Occupied	Heat/Cool/Fan NOT running	
Occupied temporarily	Heat/Cool/Fan NOT running	
Pre-occupancy purge	Fan running	
Unoccupied	Cooling system running	
Unoccupied temporarily	Cooling system running	
Standby	Cooling system running	
Unoccupied	Cooling system NOT running	OFF
Unoccupied temporarily	Cooling system NOT running	
Standby	Cooling system NOT running	ON
Non-programmable	Fan running	
Non-programmable	Fan NOT running	OFF

Thermostat Mode	A-L/A terminal: TOD
Occupied	ON
Occupied temporarily	
Temperature overrides	
Unoccupied	OFF
Unoccupied temporarily	
Standby	
Non-programmable	

Heat pump with outdoor temperature lockouts

Outdoor temperature lockouts are optional. See Installer Setup options (ISU 3120).

Backup heat allowed to run with heat pump (see table below)

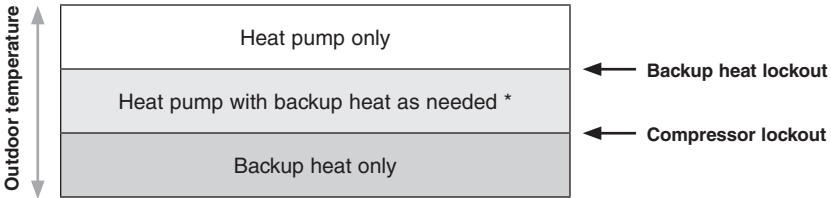

* No backup heat unless indoor temperature drops to selected Backup Heat Differential setting, or Backup Heat Upstage Timer expires. **Heat pump stays ON when backup heat turns on.**

Backup heat NOT allowed to run with heat pump (see table below)

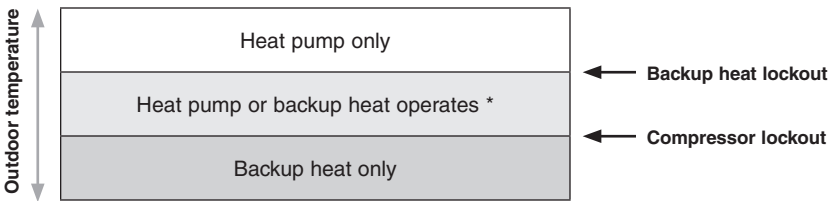

* No backup heat unless indoor temperature drops to selected Backup Heat Differential setting, or Backup Heat Upstage Timer expires. **Heat pump turns OFF when backup heat turns on.**

Heat pump and backup heat operation

Backup Heat Type	Backup Heat Operation	Backup Heat Fan Operation
Electric forced air	Allowed to run with heat pump	Thermostat controls fan
Gas or oil forced air	NOT allowed to run with heat pump	Equipment controls fan
Hot water radiant heat	Allowed to run with heat pump	[n/a]
Hot water fan coil	Selectable in installer setup	Thermostat controls fan
Other	Selectable in installer setup	Selectable in installer setup

Geothermal Radiant Heat

The thermostat can be setup to control Geothermal Radiant Heat, Geothermal Forced Air Heat and Backup Heat, all from one thermostat. The thermostat stages the equipment starting with the Geothermal Radiant Heat followed by Geothermal Forced Air Heat and then Backup Heat as needed to maintain the desired temperature. The thermostat allows you to set differential temperature settings between each stage if you want the equipment to stage a certain way (see ISU 3030 to ISU 3090).

When the Backup Heat is fossil fuel, the Geothermal Forced Air Heat turns off when the Backup Heat turns on. Geothermal Radiant Heat stays on when the fossil fuel Backup Heat turns on.

When the Backup Heat is electric, Geothermal Radiant Heat and Geothermal Forced Air Heat stay on when the electric Backup Heat turns on.



To turn off Radiant Heat during the shoulder seasons, install an outdoor reset control and connect to the Radiant Heat or switch the thermostat to Emergency Heat mode.

Basic and Advanced Temperature Control Options (ISU 3010)

Basic Options: The Installer Setup displays basic temperature control options which include Backup Heat Differential, Backup Heat Upstage Timer and Outdoor Temperature Lockouts. Note: Outdoor Temperature Lockouts only apply to Heat Pump applications.

Advanced Options: The Installer Setup displays both Basic and Advanced Options. Advanced temperature control options include Finish With High Cool Stage, Finish With High Heat Stage, Temperature Differential settings between all stages and Cycle Rate settings per stage.

 Finish With High Heat or Cool Stage - When a multi-stage heating or cooling system is used, this feature keeps the high stage of the heating or cooling equipment running until the desired setpoint is reached. Recommended setting for Geothermal Heat Pumps to allow the loop to rest.

Backup heat differential and upstage timer

A backup heat differential and backup heat upstage timer can be set on any system that has more than one type of heating equipment. See installer setup options (ISU 3070-3110).

Normal operation

When the *Backup Heat Differential* is set to Comfort, the thermostat uses backup heat as needed to keep the indoor temperature within 1° F (0.5° C) of the setpoint.

When the *Backup Heat Differential* is set to 2° F or higher, backup heat is not used unless the indoor temperature drops to the *Backup Heat Differential* setting or the *Backup Heat Upstage Timer* expires, whichever occurs first. The upstage timer starts when the highest stage of the previous equipment type turns on.

Manual temperature change

When the *Backup Heat Differential* is set to Comfort, the thermostat uses backup heat as needed to keep the indoor temperature within 1° F (0.5° C) of the setpoint.

When the *Backup Heat Differential* is set to 2° F or higher, if the primary heat is making progress as expected, backup heat will not be used to reach the new setpoint. Set to a higher number to use less backup heat (a greater difference between the current indoor temperature and the new setpoint is required to turn on backup heat). See notes below.

Programmed recovery

If the primary heat is making progress as expected, backup heat will not be used to reach the setpoint of the next program period. Backup heat is always restricted during a programmed recovery when the Adaptive Intelligent Recovery feature is used. See note below.

 During a programmed recovery (or when the temperature setpoint is changed by the user), the thermostat waits to turn on the backup heat depending on system performance, load conditions and how many degrees the temperature setpoint is changed. Backup heat will be used ONLY when the temperature is not rising quickly enough to reach the setpoint in a reasonable time.

 If the backup heat was used in the last 2 hours because the primary heat was not able to maintain the setpoint, the thermostat may turn on the backup heat earlier when the user raises the setpoint. This does NOT apply to heat pumps with fossil fuel backup heat.

Humidification

The thermostat reads the indoor humidity level and allows the user to set a humidification setting with or without window protection. The thermostat can be setup to control a humidifier in any system mode (Heat, Off, Cool [ISU 8060]). A discharge air sensor is required to humidify in the cool mode.

Humidification Control Options: (ISU 8070)

- Humidify Only When Heat is On
- Humidify Only When Fan is On
- Humidify on Demand: Thermostat Controls Fan
- Humidify on Demand: Humidifier Controls Fan

Residential dehumidification

The thermostat reads the indoor humidity level and allows the user to set a dehumidification setting. The thermostat controls the humidity level using the cooling system or a whole house dehumidifier.

Dehumidification Equipment Options: (ISU 9000)

- A/C with Low Speed Fan
- A/C with High Speed Fan
- Whole House Dehumidifier

When set for *A/C with Low Speed Fan* or *A/C with High Speed Fan*, an overcooling limit can be set from 0° to 3° F (ISU 9070). The thermostat uses the cooling system to reduce humidity by lowering the temperature up to 3° F below the current cool setpoint until the the desired humidity level is reached. If set for *A/C with Low Speed Fan*, configure U1, U2 or U3 as normally open or normally closed (ISU 9050) and wire the terminal to the Low Speed Fan terminal on the equipment. For example, if the U1, U2 or U3 terminal is normally closed, it will open when the thermostat calls for dehumidification.

Note: The thermostat will not lower the fan speed when the second stage of cooling is on.

The *Whole House Dehumidifier* option requires a dedicated unit for dehumidification. The thermostat can be setup to control dehumidification in all modes (Heat, Off, Cool [ISU 9120]).



If humidification and dehumidification are setup to operate in the same system mode (Heat, Cool, Off), and you are sensing humidity from one location, the thermostat will automatically enforce a 15% deadband between the humidification and dehumidification settings. The thermostat will automatically switch between humidification and dehumidification to maintain the desired humidity level.



If humidification and dehumidification are setup to operate in the same system mode (Heat, Cool, Off), and you are sensing humidity from two different locations using a remote wireless indoor sensor (for example, main level and crawl space), the thermostat will allow humidification and dehumidification to operate at the same time, and there is no deadband between humidification and dehumidification settings.

Commercial dehumidification

The thermostat reads the indoor humidity level and allows the user to set a dehumidification setting. The thermostat controls the humidity level using the cooling system or a dehumidifier.

Dehumidification Equipment Options: (ISU 9000)

- A/C with Low Speed Fan
- A/C with High Speed Fan
- Hot Gas Bypass
- Dehumidifier

When set for *A/C with Low Speed Fan*, *A/C with High Speed Fan* or *Hot Gas Bypass*, there are six methods of dehumidification control: (ISU 9080) See descriptions of each, below.

- 1 **Basic:** This option uses the cooling system to reach the desired humidity level. Minimum On Time, High Humidity Comfort Reset and Reheat are not used with this method. This setting is commonly used if your dehumidification equipment is Hot Gas Bypass.
- 2 **Minimum On Time (ISU 9090):** This option ensures that the compressor runs long enough to effectively reduce humidity when the cooling equipment is cycled on. The compressor will run for the minimum "on time" you set until the desired humidity level is reached.
- 3 **High Humidity Comfort Reset (ISU 9100):** This option uses the cooling system to lower the temperature up to 5° F below the current cool setpoint until the desired humidity is reached. The high humidity comfort range is from 1° to 5° F.
- 4 **High Humidity Comfort Reset with Minimum On Time (ISU 9090 and 9100):** This method uses both options above to reduce humidity while maintaining a comfortable temperature.
- 5 **Reheat (ISU 9080):** This option allows heating to run during dehumidification to help maintain a comfortable temperature. If only cooling stage 1 is used, during the "off" cycle, both cooling and heating run at the same time as needed to dehumidify without overcooling. This option cannot be used in the Heat mode. This option is effective only if using a system with the A-Coil located before the heating coil (heat exchanger).
- 6 **Reheat with Minimum On Time (ISU 9080 and 9090):** This method uses both *Reheat* and *Minimum On Time* options above to reach the desired humidity level.

The *Dehumidifier* option requires a dedicated unit for dehumidification. The thermostat can be setup to control dehumidification in all modes (Heat, Off, Cool [ISU 9120]).



Hot Gas Bypass - During a call for dehumidification, the cooling capacity will be used to remove more latent heat than sensible heat. The operation of Hot Gas Bypass varies by equipment. For more details, contact the equipment manufacturer.



Reheat can be used on heat pump applications that have a forced air backup heat source (gas, oil or electric). The thermostat will turn on the first stage of forced air backup heat during Reheat.

Southern Dehumidification Away Mode

Southern Dehumidification Away Mode protects the home when unoccupied for long periods of time during hot and humid weather by maintaining the desired humidity and temperature settings. Southern Dehumidification Away Mode options: (ISU 9180 to 9200)

- Fan Control: Auto, On or Circulate
- Low Limit Temperature Setting: The thermostat allows the cooling system to lower the indoor air to the Low Limit Temperature Setting to reach the Dehumidification Setting (ISU 9200).
- Temperature Setting: Temperature that is maintained when dehumidification is not needed.
- Dehumidification Setting: The desired humidity level while Southern Dehumidification Away Mode is active.

You can control humidity with a dehumidifier or a cooling system. If a cooling system is used, humidity is controlled by cooling indoor air to the Low Limit Temperature Setting. When the desired humidity level is reached, the system will maintain the Southern Dehumidification Away Mode temperature setting.

Ventilation

The thermostat can be set for the following ventilation types: (ISU 10000)

- ERV/HRV
- Passive (Fan Only)
- Fresh Air Damper

Ventilation Control Methods (ISU 10050)

Ventilation can be setup to meet ASHRAE or Percent On Time settings. To meet these settings, the thermostat will ventilate during calls for heat, cool and fan. If the required ventilation has not been achieved for ASHRAE or Percent On Time, the thermostat will force the ventilation equipment on.

- ASHRAE: The thermostat operates ventilation equipment to meet the ASHRAE 62.2 ventilation standard based on CFM, number of bedrooms, and square footage of the house. ASHRAE 62.2 can only be met if the ventilation equipment is running. If the ventilation equipment is off for any reason (outdoor ventilation lockouts, set up to turn Off during Sleep period, turned off by user etc.), ASHRAE 62.2 is not met during those times. See ISU 10125 to select a Ventilation Priority.
- Percent on Time: The ventilator runs based on a percentage set in the Installer Setup. For example: if set to 50%, the ventilator runs at random times during a 1 hour period until it reaches a 50% run time (approximately 30 minutes).

Indoor sensor operation

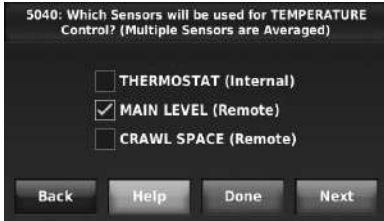

Temperature control

The thermostat can be set to respond to its internal temperature sensor, or to an optional remote indoor sensor. If multiple sensors are used, the thermostat will respond to an average of temperatures detected at each sensor.



Humidification control

If optional remote indoor sensors are installed, you can choose which sensor you want to use for humidification control. You can use a different sensor for dehumidification.



Dehumidification control

If optional remote indoor sensors are installed, you can choose which sensor you want to use for dehumidification control. For example, you can use one sensor for humidification control, and another for dehumidification.

Wireless indoor sensor

Battery level indicators (when batteries are inserted)

- **Good:** Status light flashes green for 5 seconds.
- **Low:** Status light flashes red for 5 seconds. Use fresh batteries.

Battery level indicators (during use)

- **Good:** Status light remains off.
- **Low:** Battery power will be depleted in about 2 months. Thermostat displays Low Battery warning. Status light remains off.
- **Critical:** Battery power will be depleted in about 2–3 weeks. Status light flashes red.



The Wireless Indoor Sensor is compatible only with RedLINK 2.0 thermostats. The thermostat can use up to 6 optional wireless sensors.

Alerts and diagnostics

Maintain close contact with your customers by providing more comfort and efficiency with alerts and diagnostics. Alerts and reminders can notify customers when maintenance or service is needed, and display your contact information to make it easy for them to reach you. The following are only a few of many options. Check the thermostat's on-screen menus for more.

Alerts Log

MENU > INSTALLER OPTIONS > DATA LOGS > ALERTS LOG

The thermostat saves the most recent 25 alerts. It records the date, time, alert status (snoozed, dismissed, recovered), and diagnostic information to help you identify and correct problems.

User Interactions Log

MENU > INSTALLER OPTIONS > DATA LOGS > USER INTERACTIONS LOG

Check this log to find out if a problem was caused by an accidental user error. The log shows most changes made to thermostat settings, by time and date, and describes what change was made.

The thermostat records the most recent 250 changes. You can quickly search them by date and time, or by function. This feature can be turned off if necessary, so that no user interactions are recorded.

Examples:

- * [date, time] Heat temperature set to 80° F
- * [date, time] System mode set to Off
- * [date, time] Installer setup changed — heating equipment type

Delta T Diagnostics

MENU > INSTALLER OPTIONS > SET UP DIAGNOSTICS

If a discharge and return air sensor is installed, the thermostat can track system performance over time. It measures this as "Delta T."

This can tell you if the system is performing above or below expected standards which would normally go unnoticed, and may cause unnecessary energy use. It can also detect and warn about problems early, before heating or cooling equipment fails.

The thermostat will measure and record Delta T of the system for each stage you test. This information can be used to set the proper Delta T fault limits of the system. When the system operates outside those limits multiple times, an alert is recorded in the log. If configured to do so, the system will then display an alert to the user.



Delta T Alert Sensitivity is adjustable in the Installer Setup (ISU 13180)

Delta T diagnostics is only for non-zoned forced air systems.

Replacing system components

To replace an Equipment Interface Module (EIM)

Follow steps below to disconnect the thermostat and RedLINK accessories. See pages 5-6 to re-link devices.

At the Thermostat

- 1 Press *MENU > INSTALLER OPTIONS*, then enter date code when prompted (printed on back of thermostat). Or press *MENU > EQUIPMENT STATUS* to find the date code.
- 2 Scroll down to select *WIRELESS DEVICE MANAGER*.
- 3 Press *REMOVE DEVICE*, then select *THIS THERMOSTAT* to remove.

At the Portable Comfort Control

- 1 Press and hold the blank space (or arrow if present) in the lower right hand corner of the screen until the display changes.
- 2 Press *REMOVE*, then *YES* to disconnect from the old EIM.

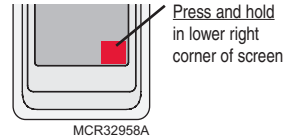

At the Indoor Sensor, RedLINK Internet Gateway, Entry/Exit Remote, Vent Boost Remote or TrueSTEAM Wireless Adapter

Press and hold the *CONNECT* button on the RedLINK accessory until the status light glows amber (hold for about 10 seconds). This will disconnect the device from the old EIM or thermostat.

To replace a thermostat

At the EIM (Skip this step if no EIM is used)

Press and hold the *CONNECT* button on the EIM until the status light glows amber (hold for about 10 seconds). This will disconnect ALL devices from the EIM.

At the Portable Comfort Control

- 1 Press and hold the blank space (or arrow if present) in the lower right hand corner of the screen until the display changes.
- 2 Press *REMOVE*, then *YES* to disconnect from the old thermostat.

At the Indoor Sensor, RedLINK Internet Gateway, Entry/Exit Remote, Vent Boost Remote or TrueSTEAM Wireless Adapter

Press and hold the *CONNECT* button on the RedLINK accessory until the status light glows amber (hold for about 10 seconds). This will disconnect the device from the old thermostat.

To remove accessories from an EIM or thermostat

At the Thermostat

- 1 Press *MENU > INSTALLER OPTIONS*, then enter date code when prompted (print on back of thermostat). Or press *MENU > EQUIPMENT STATUS* to find the date code.
- 2 Scroll down to select *WIRELESS DEVICE MANAGER*.
- 3 Press *REMOVE DEVICE*, then select the device you want to remove.

OR: At the EIM

Press and hold the *CONNECT* button on the EIM until the status light glows amber (hold for about 10 seconds). This will disconnect ALL devices from the EIM.



If the THX9321 thermostat is setup without an EIM, all thermostat settings must be reset before it can be used with an EIM. Press *MENU > INSTALLER OPTIONS*, scroll down to select *ADVANCED OPTIONS*, then press *RESTORE FACTORY DEFAULTS*.

Specifications & replacement parts

Operating Ambient Temperature

- Thermostat:** 32 to 120° F (0 to 48.9° C)
- Portable Comfort Control:** 32 to 120° F (0 to 48.9° C)
- Wireless Outdoor Sensor:** -40 to 140° F (-40 to 60° C)
- Wireless Indoor Sensor:** 0 to 120° F (-17.8 to 48.9° C)
 - For Optimal Battery Life: 35 to 114° F (1.7 to 45.6° C)
- Equipment Interface Module:** -40 to 165° F (-40 to 73.9° C)
- Return Air Sensor:** 0 to 200° F (-17.8 to 93.3° C)
- Discharge Air Sensor:** 0 to 200° F (-17.8 to 93.3° C)
- RedLINK Internet Gateway:** 32 to 120° F (0 to 48.9° C)

Operating Relative Humidity

- Thermostat:** 5% to 90% (non-condensing)
- Portable Comfort Control:** 5% to 90% (non-condensing)
- Wireless Outdoor Sensor:** 0% to 100% (condensing)
- Wireless Indoor Sensor:** 5% to 90% (non-condensing)
- Equipment Interface Module:** 5% to 95% (non-condensing)
- RedLINK Internet Gateway:** 5% to 95% (non-condensing)

Physical Dimensions (height, width, depth)

- Thermostat:** 3-7/8 x 6-13/16 x 1-7/16 inches (99 x 173 mm x 36 mm)
- Equipment Interface Module:** 9-5/16 x 4-13/16 x 1-19/32 inches (91 x 147 x 42 mm)
- Wireless Outdoor Sensor:** 5 x 3-1/2 x 1-11/16 inches (127 x 89 x 43 mm)
- Wireless Indoor Sensor:** 2-7/8 x 1-7/8 x 15/16 inches (74 x 48 x 24 mm)
- Portable Comfort Control:** 6-1/4 x 3-1/8 x 1-5/8 inches (158 x 80 x 38 mm)
- RedLINK Internet Gateway:** 6 x 4-7/8 x 2-1/2 inches (152 x 124 x 64 mm)

Electrical Ratings

Terminal	Voltage (50/60 Hz)	Max. Current Rating
W - O/B	18 to 30 VAC	1.00A
W - O/B (EIM only)	18 to 30 VAC and 750 mVDC	1.00A
Y (cooling)	18 to 30 VAC	1.00A
G (fan)	18 to 30 VAC	0.50A
W2 - Aux 1 (heating)	18 to 30 VAC	0.60A
Y2 (cooling)	18 to 30 VAC	0.60A
W3 - Aux 2	18 to 30 VAC	1.00A
A-L/A (Output)	18 to 30 VAC	1.00A
U1, U1	30 VAC max.	0.50A
U2, U2	30 VAC max.	0.50A
U3, U3	30 VAC max.	0.50A

Accessories & Replacement Parts

Item	Part Number
Equipment Interface Module	THM5421R1013
RedLINK Internet Gateway	THM6000R1002
Wireless Entry/Exit Remote	REM1000R1003
Wireless Vent and Filter Boost Remote	HVC20A1000
Portable Comfort Control	REM5000R1001
Occupancy Sensor for Remote Setback	WSK-24
Wireless Outdoor Sensor	C7089R1013
Wireless Indoor Sensor	C7189R1004
Wired Outdoor Sensor 10k ohm NTC	C7089U1006
Wired Wall-mount Indoor Sensor 10k ohm NTC	C7189U1005
Wired Flush-mount Indoor Sensor 20k ohm NTC	C7772A1004, C7772A1012
Wired Wall-mount Indoor Sensor 20k ohm NTC	TR21
Wired Wall-mount Indoor Sensor 10k ohm NTC	TR21-A
Discharge or Return Air Sensor 10k ohm NTC	C7735A1000
Discharge or Return Air Sensor 20k ohm NTC	C7041
Discharge or Return Air Sensor 20k ohm NTC	C7770A1006
Cover Plate (covers marks left by old thermostats)	50028399-001
Battery Pack (For demo use only)	THP1000A1007
Wire Saver Module	THP9045A1023

Regulatory information

FCC Compliance Statement (Part 15.19) (USA only)

This device complies with Part 15 of the FCC Rules. Operation is subject to the following two conditions:

- 1 This device may not cause harmful interference, and
- 2 This device must accept any interference received, including interference that may cause undesired operation.

FCC Warning (Part 15.21) (USA only)

Changes or modifications not expressly approved by the party responsible for compliance could void the user's authority to operate the equipment.

FCC Interference Statement (Part 15.105 (b)) (USA only)

This equipment has been tested and found to comply with the limits for a Class B digital device, pursuant to Part 15 of the FCC Rules. These limits are designed to provide reasonable protection against harmful interference in a residential installation. This equipment generates uses and can radiate radio frequency energy and, if not installed and used in accordance with the instructions, may cause harmful interference to radio communications. However, there is no guarantee that interference will not occur in a particular installation. If this equipment does cause harmful interference to radio or television reception, which can be determined by turning the equipment off and on, the user is encouraged to try to correct the interference by one of the following measures:

- Reorient or relocate the receiving antenna.
- Increase the separation between the equipment and receiver.
- Connect the equipment into an outlet on a circuit different from that to which the receiver is connected.
- Consult the dealer or an experienced radio/TV technician for help.

Equipment interface module, thermostats and outdoor sensor

To comply with FCC and Industry Canada RF exposure limits for general population/ uncontrolled exposure, the antenna(s) used for these transmitters must be installed to provide a separation distance of at least 20 cm from all persons and must not be co-located or operating in conjunction with any other antenna or transmitter.

Portable Comfort Control

This portable transmitter with its antenna complies with FCC and Industry Canada RF exposure limits for general population/ uncontrolled exposure. This device must not be co-located or operating in conjunction with any other antenna or transmitter.

Section 7.1.2 of RSS-GEN

Under Industry Canada regulations, this radio transmitter may only operate using an antenna of type and maximum (or lesser) gain approved for the transmitter by Industry Canada. To reduce potential radio interference to other users, the antenna type and its gain should be so chosen that the equivalent isotropically radiated power (e.i.r.p.) is not more than that necessary for successful communication.

Section 7.1.3 of RSS-GEN

Operation is subject to the following two conditions:

- 1 this device may not cause interference, and
- 2 this device must accept any interference, including interference that may cause undesired operation of the device.