

RESIDENTIAL POWER DIRECT VENT GAS-FIRED WATER HEATERS (EQUIPPED WITH FVIR TECHNOLOGY) OWNER'S MANUAL SUPPLEMENT

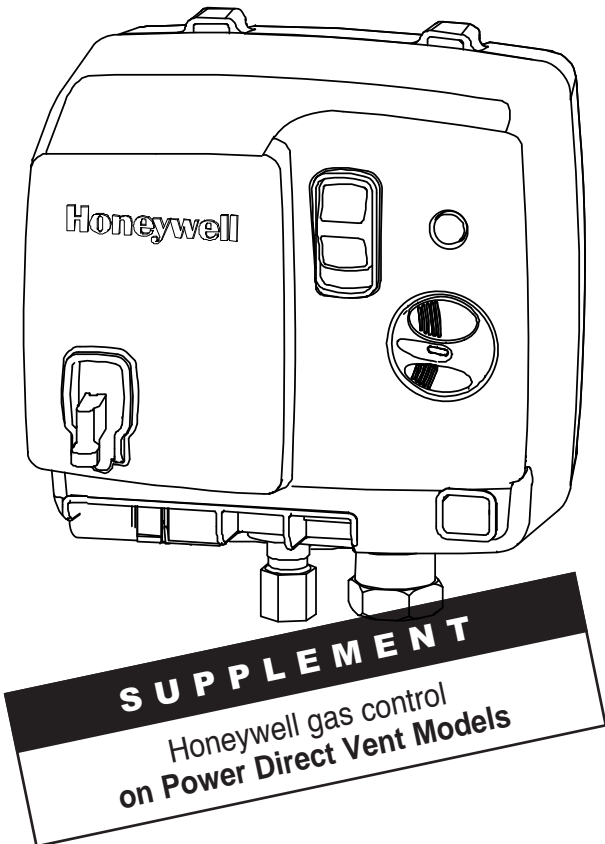

⚠ WARNING

This water heater **IS NOT** design certified for installation in a manufactured (mobile) home or for installation outdoors.

⚠ WARNING

If the information in these instructions is not followed exactly, a fire or explosion may result causing property damage, personal injury, or death.

DO NOT store or use gasoline or other flammable vapours and liquids in the vicinity of this or any other appliance.

WHAT TO DO IF YOU SMELL GAS

- **DO NOT** try to light any appliance.
- **DO NOT** touch any electrical switch.
- **DO NOT** use any phone in your building.
- **From a neighbour's phone, immediately call your gas supplier.** Follow the gas supplier's instructions.
- If you cannot reach your gas supplier, immediately call the fire department at 911.

Installation and service must be performed by a qualified installer, service agency, or the gas supplier.

IMPORTANT

READ THESE INSTRUCTIONS CAREFULLY BEFORE BEGINNING THE INSTALLATION. PROPER INSTALLATION WILL PROVIDE SAFE & EFFICIENT SERVICE, AND AVOID NEEDLESS EXPENSE NOT COVERED BY THE WARRANTY. READ THE PRODUCT WARRANTY IN THE OWNER'S MANUAL AND REMEMBER TO FILL OUT AND RETURN TO THE MANUFACTURER, ALL RELEVANT WARRANTY CARDS AND CERTIFICATES. SHOULD YOU HAVE ANY QUESTIONS, PLEASE CONTACT YOUR LOCAL DEALER OR REFER TO THE **GETTING SERVICE FOR YOUR WATER HEATER** SECTION OF THE OWNER'S MANUAL.

SAVE THIS SUPPLEMENT FOR FUTURE REFERENCES.

For your records, write the model and serial number here:

Model # _____

Serial # _____



C US
LOW LEAD
CONTENT



Water Piping Installation

Minimum Slope
1/4"/foot (21mm/m)

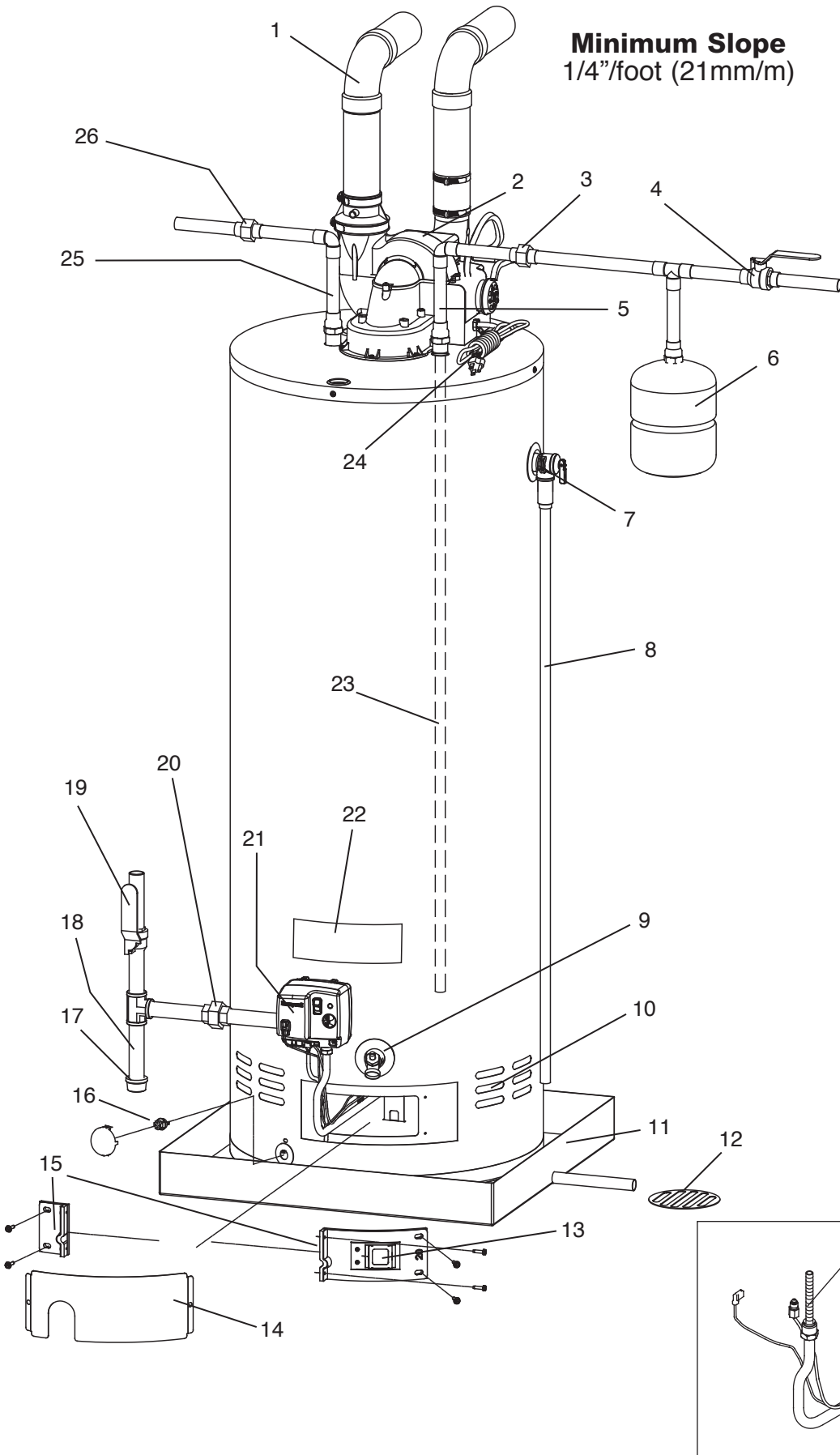

- 1) Vent pipe
 - 2) Power Direct vent assembly
 - 3) Union
 - 4) Cold water manual shut-off valve
 - 5) Cold water inlet
 - 6) Expansion tank
 - 7) Temperature and pressure-relief valve
 - 8) Overflow tube
 - 9) Drain valve
 - 10) Combustion air intake holes
 - 11) Drain pan
 - 12) Free-flowing floor drain
 - 13) Sight glass
 - 14) Outer access door
 - 15) Inner access door
 - 16) Flammable vapour sensor
 - 17) Cap
 - 18) Drip leg (Sediment trap)
 - 19) Gas supply manual shut-off valve
 - 20) Union
 - 21) Gas control valve
 - 22) Rating plate
 - 23) Dip tube
 - 24) 12' Power cord (3.86 m)
 - 25) Hot water outlet
 - 26) Union
-
- 27) Pilot assembly
 - 28) Burner orifice
 - 29) Burner
 - 30) Spring (For LP models only)

FOR YOUR SAFETY READ BEFORE OPERATING

WARNING: If you do not follow these instructions exactly, a fire or explosion may result causing property damage, personal injury or loss of life.

- A. This appliance is equipped with an ignition device which automatically lights the pilot.
DO NOT TRY to light the pilot by hand.
- B. **BEFORE** operating smell all around the appliance area for gas. Be sure to smell next to the floor because some gas is heavier than air and will settle on the floor.
WHAT TO DO IF YOU SMELL GAS:
- **DO NOT** try to light any appliance.
 - **DO NOT** touch any electric switch; do not use any phone in your building.
 - Immediately call your gas supplier from a neighbor's phone. Follow the gas supplier's instructions.
 - If you cannot reach your gas supplier, call the fire department.
- C. Use only your hand to slide the gas control switch or turn the thermostat dial. Never use tools. If the switch or dial cannot be moved by hand, don't try to repair it, call a qualified service technician. Force or attempted repair may result in a fire or explosion.
- D. **DO NOT** use this appliance if any part has been under water. Immediately call a qualified service technician to inspect the appliance and to replace any part of the control system and any gas control which has been under water.

OPERATING INSTRUCTIONS

1. **STOP!** Read the safety information above (to the left) on this label.
2. Slide the "ON/OFF" switch located on the gas control to the "OFF" position.
3. Turn OFF all electric power to the appliance.

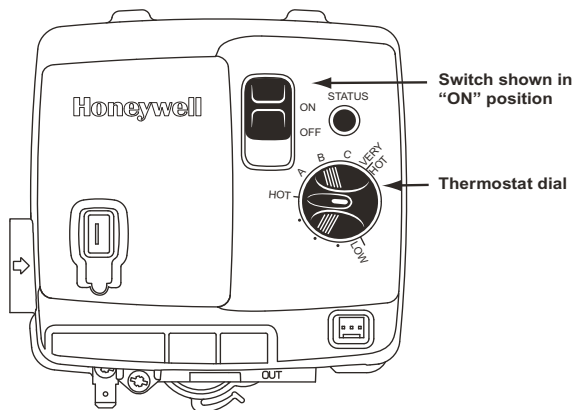

4. Turn the thermostat dial counterclockwise ↺ to the lowest setting.
5. This appliance has an automatic spark ignition system. **DO NOT** attempt to light the pilot by hand.
6. Wait five (5) minutes to clear out any gas. Then smell for gas, including near the floor. If you smell gas, **STOP!** Follow "B" in the safety information above (to the left) on this label. If you don't smell gas, go to the next step.
7. Turn ON electric power to the appliance.
8. Slide the "ON/OFF" switch located on the gas control to the "ON" position.
9. Turn the thermostat dial clockwise ↻ to the desired setting.
10. If the appliance will not operate, follow the instructions "To Turn Off Gas To Appliance" and call your service technician or gas supplier.

TO TURN OFF GAS TO APPLIANCE

1. Turn the thermostat dial counterclockwise ↺ to the lowest setting.
2. Slide the "ON/OFF" switch located on the gas control to the "OFF" position.
3. Turn OFF all electric power to the appliance if service is to be performed.

Water Temperature Regulation

⚠ WARNING

The higher the temperature setting, the greater the risk of scalding. Hot water can cause third degree burns in under one (1) second at 160°F (71°C), in five (5) seconds at 140°F (60°C), and in thirty (30) seconds at 130°F (54°C). In households where there are children, physically challenged individuals, or seniors, mixing valves for point of use are necessary as means of reducing the scalding potential of hot water.

The thermostat dial is adjusted to its lowest setting when shipped from the factory. To adjust the thermostat, turn the dial clockwise ↻ to the desired setting. To maximize the efficiency of this water heater and reduce the risk of scalding, it is recommended that the gas control valve be set at the "HOT" setting, which represents approximately 120°F (49°C).

When hot water is drawn from the tank in frequent short bursts, a condition known as "stacking" is created. "Stacking" is the result of increased cycling of the burner and can produce very hot water tem-

peratures at the hot water outlet. Always remember to check the hot water coming out of any faucet with your hand before use. This will reduce the risk of scalding-related injuries.

The gas control valve pictured in this manual is equipped with a resettable type automatic high temperature cut-off. Should the temperature of the water exceed 189°F (87°C), the high temperature cut-off will automatically shut off the gas supply to the water heater. If this situation occurs, the gas control valve must be reset by a qualified service technician.

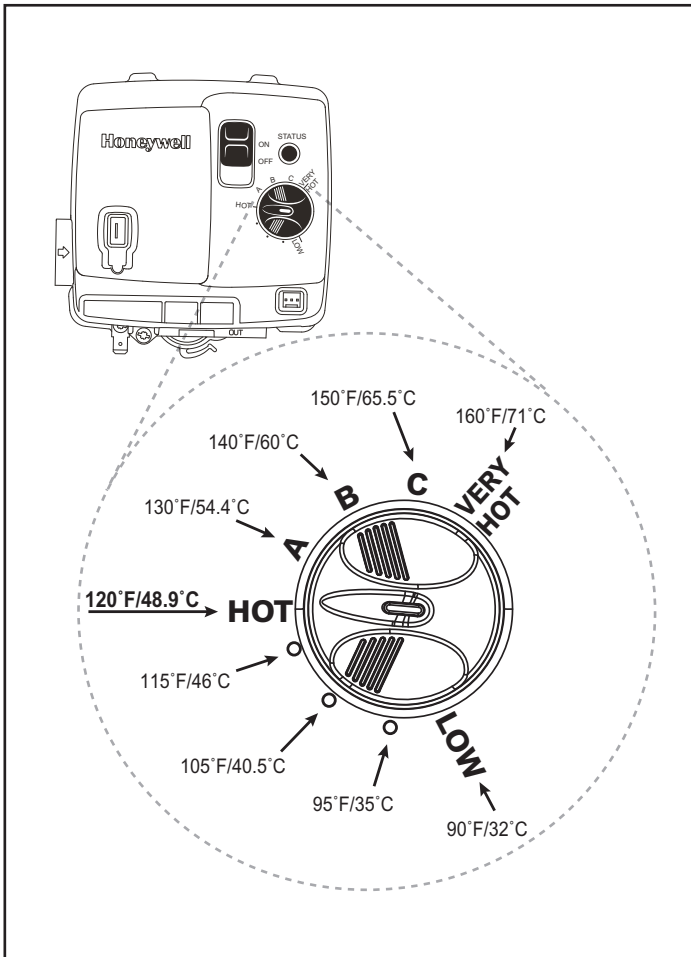

Safety System

This water heater is equipped with a flammable vapour sensor (FV) that will shut it down in the event of a flammable vapour incident. It is a safety feature that may prevent property damage, personal injury, or death.

The FV sensor is located on the front left bottom of the exterior casing of the water heater. The FV sensor is protected from shock and contaminants by a robust plastic cover. The function of the FV sensor is to detect the presence of flammable vapours before they enter the combustion chamber and ignite. If the FV sensor detects the presence of flammable vapours while the water heater is operating, the gas

control will switch to lock-out mode and the water heater will shut down. If the water heater is not operating when the flammable vapours are detected, the control will switch to lock-out mode and prevent the water heater from lighting.

After a flammable vapour incident has occurred and the flammable vapours have dissipated, the FV sensor is designed to automatically reset itself. The Intelli-Vent™ gas control however, will have gone into lock-out mode and will need to be manually reset. A qualified service technician must be called to determine if flammable vapours entered the combustion chamber and ignited. In most instances, there will not have been ignition of flammable vapours inside the combustion chamber because the FV sensor will have detected these vapours and shut down the water heater. In this case, the Intelli-Vent™ gas control can be reset and the water heater may resume normal operation. On the other hand, if the flammable vapours ignited inside the combustion chamber, the water heater may need to be replaced. The technician will be able to determine whether or not the water heater needs to be replaced based on the amount of flammable vapours that entered the combustion chamber and the damage to the water heater from the resulting fire.

Burner Ignitor Assembly

Every three (3) months, check the burner and flame ignitor pilot assembly. Remove the outer access door and look through the sight glass to examine the flames. A soft blue flame indicates proper gas combustion. A yellow tipped flame indicates poor combustion. With a vacuum cleaner, remove any dust, lint, and dirt accumulation on or around the combustion chamber.

Wiring Diagram (all Power Direct Vent models except UG50-62 and GG50-62)

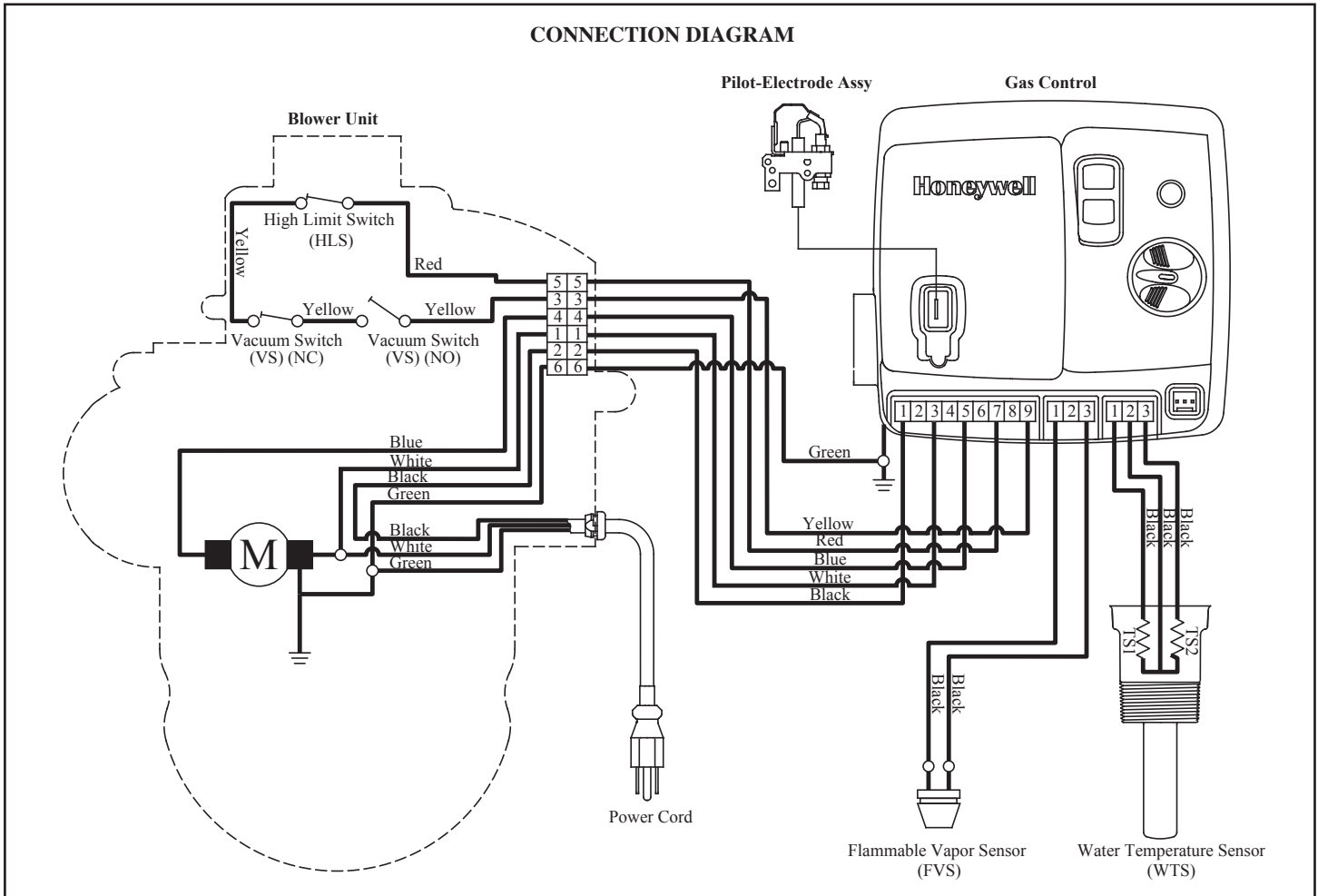
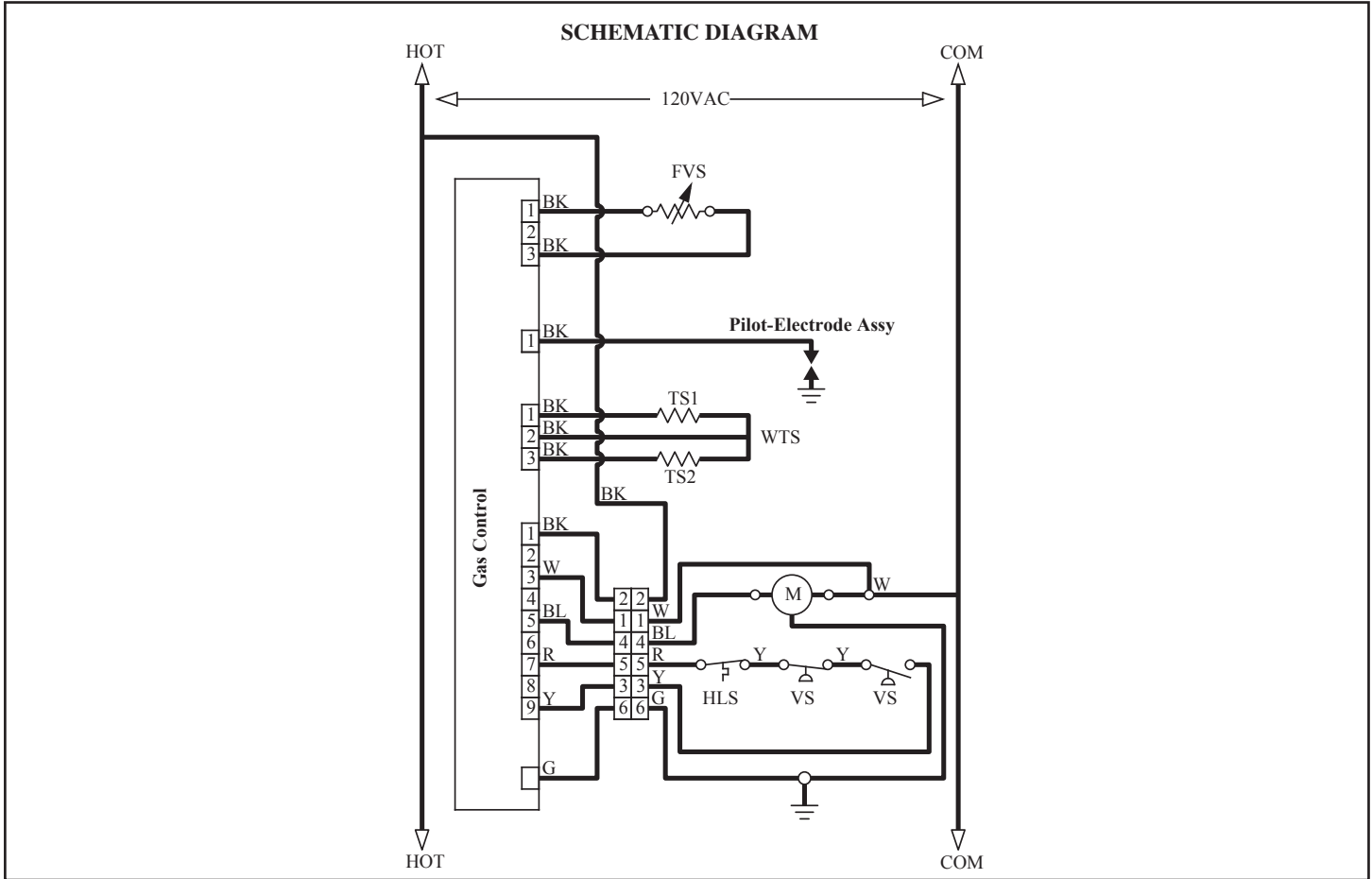

LED Status Codes

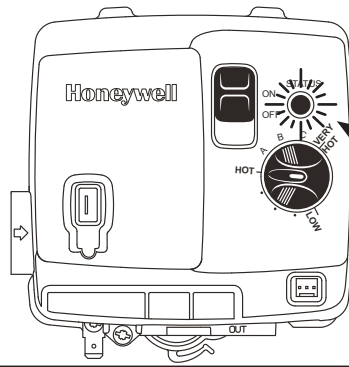

















Light-emitting diode (LED)

Code example

6 X  + PAUSE 3 sec.

Six – Two flash, 3 sec. pause

LED FLASH SEQUENCE	CONTROL STATUS	CAUSE	REMEDY
1 • None	No electrical power to control	<ul style="list-style-type: none"> Control power switch in "OFF" position. Supply voltage interrupted. 	<ul style="list-style-type: none"> Slide the switch to "ON" position. Supply power to the water heater.
2 1 X  + PAUSE 4 sec.	Idle (no call for heat, no faults)	<ul style="list-style-type: none"> Thermostat is satisfied. 	<ul style="list-style-type: none"> No remedy required.
3 	Call For Heat (no faults)	<ul style="list-style-type: none"> Water temperature is below set-point of thermostat. 	<ul style="list-style-type: none"> No remedy required.
4 1 X  + PAUSE 1 sec.	Weak Pilot Flame Current (in Idle only, no faults)	<ul style="list-style-type: none"> Unstable pilot. Pilot tube restriction. Oxidation build-up on electrode. Pilot wire damage or bad connection. Low gas supply pressure. 	<ul style="list-style-type: none"> Check gas pressure, pressure supply and voltage supply. Replace pilot assembly.
5 2 X  + PAUSE 3 sec.	Pressure Switch Failed Closed	<ul style="list-style-type: none"> Pressure switch tube blockage. Faulty pressure switch. 	<ul style="list-style-type: none"> Replace tube or clear blockage. Check pressure switch wiring. Replace pressure switch.
6 3 X  + PAUSE 3 sec.	Pressure Switch Failed Open	<ul style="list-style-type: none"> Vent blockage or improper vent configuration. Blower improper operation. Temperature switch on blower open. Pressure switch tube blockage. Faulty pressure switch. 	<ul style="list-style-type: none"> Check for obstruction in the vent system. Check pressure switch wiring. Replace pressure switch. Replace blower temperature switch. Replace blower.
7 4 X  + PAUSE 3 sec.	TCO Limit Lockout	<ul style="list-style-type: none"> Thermal well fault. Gas control fault. Tank is not filled with water or excessive sediment. 	<ul style="list-style-type: none"> Reset gas control and check for proper operation. Make sure the tank is full of water. Replace thermal well.
8 5 X  + PAUSE 3 sec.	Flame Out Of Sequence (false flame present)	<ul style="list-style-type: none"> Pilot or burner gas valve has failed open. 	<ul style="list-style-type: none"> Replace gas control.
9 6 X  + PAUSE 3 sec.	Failed Trial For Ignition - Soft Lockout	<ul style="list-style-type: none"> Unstable pilot. Pilot tube restriction. Oxidation build-up on electrode. Pilot wire damage or bad connection. Low gas supply pressure. 	<ul style="list-style-type: none"> Check gas pressure, pressure supply and voltage supply. Replace pilot assembly.
10 6 X  + PAUSE 3 sec.	Recycle Limit - PS/Limit opened - Soft Lockout	<ul style="list-style-type: none"> Vent blockage or improper vent configuration. Excessive wind at vent termination. Blower improper operation. Temperature switch on blower open. Pressure switch tube blockage. Faulty pressure switch. 	<ul style="list-style-type: none"> Check for obstruction in the vent system and compliance with venting configurations. Check pressure switch wiring. Replace pressure switch. Replace blower temperature switch. Replace blower.
11 6 X  + PAUSE 3 sec.	Recycle Limit - Flame Lost - Soft Lockout	<ul style="list-style-type: none"> Unstable pilot. Pilot tube restriction. Oxidation build-up on electrode. Pilot wire damage or bad connection. Low gas supply pressure. Insufficient combustion air. 	<ul style="list-style-type: none"> Check gas pressure, pressure supply and voltage supply. Check for proper combustion air. Replace pilot assembly.
12 6 X  + PAUSE 3 sec.	Flame out of Sequence Sensed - Soft Lockout	<ul style="list-style-type: none"> Gas valve stuck in open position. 	<ul style="list-style-type: none"> Replace gas control.
13 7 X  + PAUSE 3 sec.	Flammable Vapor Sensor Lockout	<ul style="list-style-type: none"> Flammable vapor was detected near the water heater. FV Sensor has failed. 	<ul style="list-style-type: none"> Verify no gasoline or flammable vapors are present. Reset control using ON/OFF switch on the gas control. Replace Flammable vapour sensor.
14 8 X  + PAUSE 3 sec.	FVS Fault Detected	<ul style="list-style-type: none"> FV sensor is out of specification. FV sensor wiring is faulty. 	<ul style="list-style-type: none"> Replace FV sensor. Replace the FV sensor wiring. Replace the gas control.
15 8 X  + PAUSE 3 sec.	Temperature Sensor Fault Detected	<ul style="list-style-type: none"> Thermal well fault. 	<ul style="list-style-type: none"> Check thermal well wiring connection. Replace thermal well.
16 8 X  + PAUSE 3 sec.	Electronics Fault Detected	<ul style="list-style-type: none"> Thermal well fault or gas control fault. 	<ul style="list-style-type: none"> Replace thermal well. Replace gas control.
17 8 X  + PAUSE 3 sec.	Valve Fault Detected	<ul style="list-style-type: none"> Gas control needs to be reset or has been damaged. 	<ul style="list-style-type: none"> Cycle power to gas control. Replace gas control.